

AUX

Installation

Operation

Instruction Manual

Air Handling Unit Application Kit

- Installation should only be carried out by qualified technicians.
- For your convenience, please read this manual carefully and carry out all instructions in full.
- Please keep this manual in good condition for your reference.

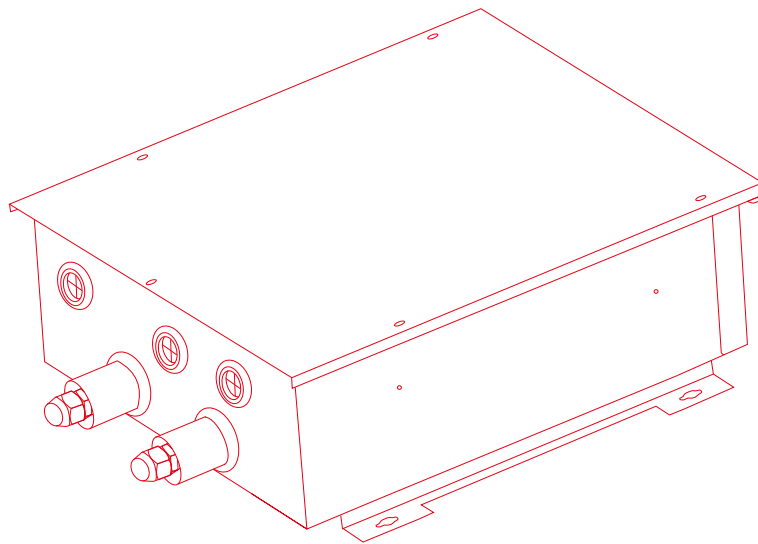

Content

1.Safety Precautions	1
2.Installation Information	2
3.Attached Fittings	2
4.External Appearance	3
5.AHU-KIT Structure Diagram	4
6.AHU-KIT Installation	5
7.Definition Of Each Dial Switch	15
8.Controller Selection	17
9. Trouble Shooting	21

All pictures in this manual are for reference only. Regret for no further announcement if there is any change of this manual caused by product improvement.

Safety Precautions

● General Information

Within the policy of continuous improvement of its products, we reserve the right to make changes at any time without prior notification and without being compelled to introducing them into products subsequently sold. This document may therefore have been subject to amendments during the life of the product.

we make every effort to offer correct, up-to-date documentation. Despite this, printing errors cannot be controlled by us and are not its responsibility.

● Safety Information

Be aware that AHU-KIT has to be combined with ARV Series outdoor unit only. Use R410A refrigerant.

- R410A is a quasi-azeotrope of two refrigerants. Make sure to charge liquid one when adding refrigerant. (If you charge gaseous refrigerant, it may affect the capacity and reliability of the product as a result of change in formation of the refrigerant.)
- When using R410A, moisture or foreign substances may affect the capacity and reliability of the product. Safety precautions must be taken when installing the refrigerant pipe.

•Applied symbols

WARNING

The text following this symbol contains information and instructions relating directly to your safety.

CAUTION

The text following this symbol contains information and instructions relating directly to personal safety or unit damage.

•Additional information about safety

WARNING

- This appliance can be used by children aged from 8 years and above and persons with reduced physical, sensory or mental capabilities or lack of experience and knowledge if they have been given supervision or instruction concerning use of the appliance in a safe way and understand the hazards involved. Children shall not play with the appliance. Cleaning and user maintenance shall not be made by children without supervision.(Only for the AC with CE-MARKING)
- This appliance is not intended for use by persons (including children) with reduced physical, sensory or mental capabilities, or lack of experience and knowledge, unless they have been given supervision or instruction concerning use of the appliance by a person responsible for their safety. Children should be supervised to ensure that they do not play with the appliance.(Except for the AC with CE-MARKING)
- We are not able to foresee all the circumstances which may result in a potential danger,turn off the power before installation, service, and cleaning.
- Do not pour water in the indoor or outdoor unit. These products are fitted with electric components. If water comes into contact with electric components, this will cause a serious electric shock.
- Do not open the service cover or access panel of the indoor and outdoor units without disconnecting the main power supply.
- In the event of fire, switch off the mains, put out the fire immediately and contact your service supplier.
- Check that the earth cable is correctly connected, Do not connect the earth wire to the gas pipe, water pipe, lighting rod or telephone wire.
- Connect the unit to a circuit breaker of the specified capacity.

CAUTION

- Manufacturer is not responsible for accidents due to incorrect installation by unqualified person.
- Install the outdoor unit correctly according to the installation manual.
- If the power cable or cord is damaged, the manufacturer, a qualified service technician must replace it to avoid a potential risk.
- Attach the cover securely so that the electrical component box cover does not get loosen.
- The installation must be done by the manufacturer or its service agent or a similar qualified person in order to avoid a hazard.

- When there were leakage during installation, you must ventilate the area, because refrigerant leaks may hinder respiration as the gas displaces the air in the room and toxic gas may generate when refrigerant gas contacts with fire.
- Fit the indoor unit, the outdoor unit, the remote control and the cable at a minimum of 3 metres away from sources of strong radiation from electromagnetic waves, such as medical equipment.
- If the circuit breaker or supply fuse of the unit comes on frequently, stop the system and contact the service supplier.
- Do not place any foreign material (branches, sticks, etc.) in the air inlet or outlet of the unit. These units are fitted with high speed fans and contact with any object is dangerous.
- This appliance must be used only by adult and capable people, having received the technical information or instructions to handle this appliance properly and safely. Children should be supervised to ensure that they do not play with the appliance.

Installation Information







1. To install properly, please read this "installation manual" at first.
2. The air conditioner must be installed by qualified persons.
3. When installing the AHU-KIT or its connection piping, please follow this manual as strictly as possible.
4. If the air conditioner is installed on a metal part of the building, it must be electrically insulated according to the relevant standards to electrical appliances.
5. When all the installation work is finished, please turn on the power only after a thorough check.

Installation Order

- ①Select the location; ②Install the AHU-KIT; ③Install the outdoor unit; ④Install the connection piping;
- ⑤Wiring; ⑥Test operation.

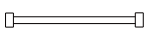
Attached Fittings

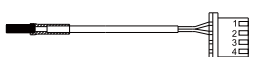
Please check whether the following fittings are of full scope. If there are some spare fittings, please restore them carefully.

Name	Shape	Quantity
Installation manual		1
Wired controller		1
Wired controller installation manual		1
Communication cable		1*10m
Liquid pipe and room temperature sensor		1*10m
Gas pipe temperature sensor		1*10m
Copper nut		2

External Appearance

The AHU-KIT has two models, the AHU-KIT contains EXV component and electrical control box.

ARVK-01A (10HP)

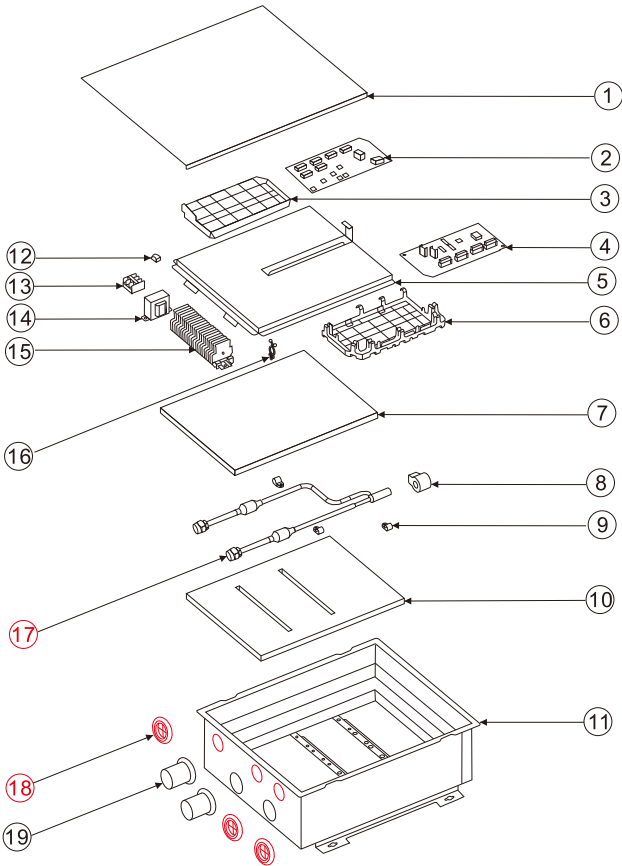

NO.	Part Name	Quantity
1	AHU-KIT cover	1
2	Main PCB	1
3	Main PCB installation basement	1
4	Expansion PCB	1
5	Electronic control basement	1
6	Expansion PCB installation basement	1
7	Upper insulation cotton	1
8	Electric expansion valve coil	1
9	Pipe clamp	3
10	Lower insulation cotton	1
11	AHU-KIT sheet metal components	1
12	Power line holding	1
13	3 bits terminal board	1
14	Transformer	1
15	38 bits terminal board	1
16	Buckle	1
17	Electric expansion valve body	1
18	Rubber ring(φ 25)	3
19	Rubber ring(φ 43)	2

ARVK-02A (20HP)

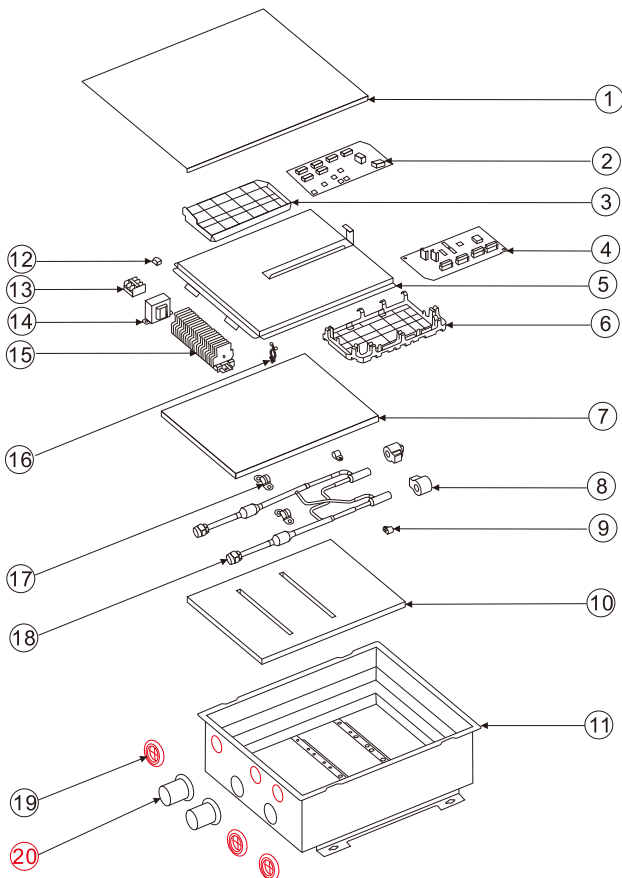

NO.	Part Name	Quantity
1	AHU-KIT cover	1
2	Main PCB	1
3	Main PCB installation basement	1
4	Expansion PCB	1
5	Electronic control basement	1
6	Expansion PCB installation basement	1
7	Upper insulation cotton	1
8	Electric expansion valve coil	2
9	Pipe clamp	2
10	Lower insulation cotton	1
11	AHU-KIT sheet metal components	1
12	Power line holding	1
13	3 bits terminal board	1
14	Transformer	1
15	38 bits terminal board	1
16	Buckle	1
17	Rubber holding	2
18	Electric expansion valve body	1
19	Rubber ring(φ 25)	3
20	Rubber ring(φ 43)	2

AHU-KIT Structure Diagram

● Example of pipeline connection

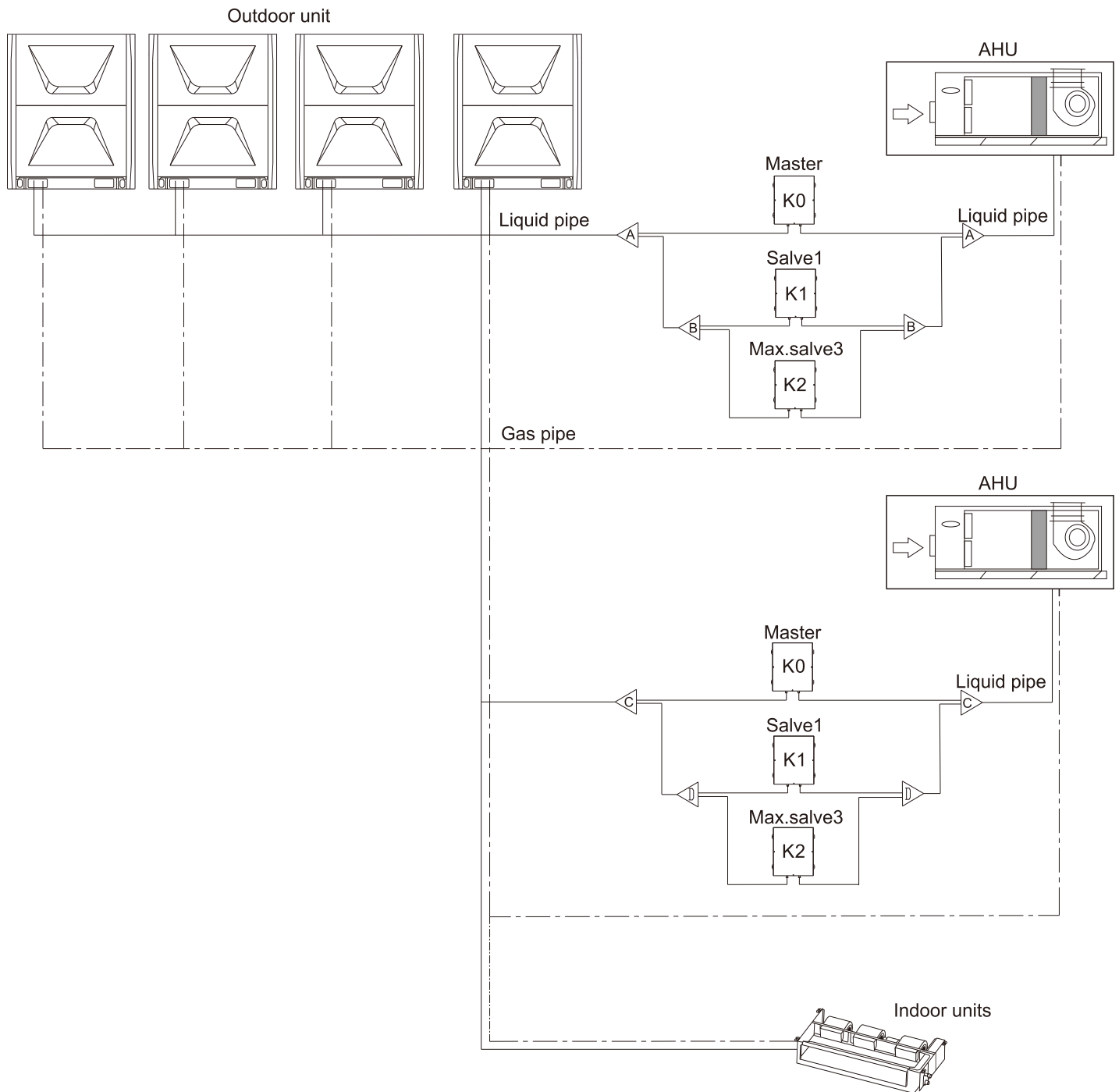

NOTES:

1. When mixed connected with other IDUs, the total capacity of IDU and AHU should be less than 100% of ODU, and the capacity of AHU should be less than 30% of the total capacity.
2. When individually connected with other ODU, the total capacity AHU (fresh air) should be less than 100% of ODU.
3. When the AHU-KIT is put outside, some protection which can avoid the rain is preferred.
4. Can communicate with ARV outdoor units, other brand AHU board or indoor units with AC fan motor, realized combination control.
5. Can only connect to R410A refrigerant system.
6. Only the master AHU-KIT can be controlled even when AHU-KITs are in parallel connection.
7. When choose pressure setting of the third party controller, there can only be one master AHU-KIT in this system.

● Recommended AHU size

Model	Indoor unit capacity(kW)	DX coil Volume dm ³ (min-max)	Reference air volume (m ³ /h)	Max. air volume (m ³ /h)
ARVK-01A	11.2-14	2.1-2.6	2000	3000
	14-18	2.6-3.3	2300	3800
	18-20	3.3-3.7	2700	4300
	20-25	3.7-4.6	3000	5400
	25-30	4.6-5.5	3800	6400
	30-36	5.6-6.6	4500	7700
ARVK-02A	36-40	6.6-7.4	5500	8600
	40-45	7.4-8.3	6000	9700
	45-50	8.3-9.2	7000	10800
	50-56	9.2-10.3	8000	12000

NOTES:

- 1.Cooling Capacity: indoor temp.27°CDB,19°CWB,outdoor temp.35°CDB,24°CWB,Equivalent piping length : 7.5m, level difference: 0m.
- 2.Heating Capacity: Indoor temp.20°CDB, outdoor temp.7°CDB,6°CWB/Equivalent piping length :7.5m, level difference: 0m.
- 3.All the above specification will be changed due to product performance improvement. We reserve the right to change product design without prior notice.
- 4.The heat exchanger of air processor unit meets the requirements of R410A refrigerant working medium, and its working pressure is 4.3MPa.
- 5.The quantity of heat exchanger rows: no more than 4 rows are recommended. If the air volume & capacity of AHU out of the above table, it is necessary to consult with R&D and overseas technology.
- 6.The outer diameter of copper tube of heat exchanger shall not be greater than 12.7mm, and 9.52mm is recommended.
7. The piping length of each separate refrigerant circuit which after the distributor shall not exceed 15m, which needs to be consulted for R&D and overseas technology (see the table below).

Diameter of AHU heat exchanger	The piping length of each separate refrigerant circuit which after the distributor		
	Recommended use	Need to consult R & D and overseas technology	Prohibition of use
φ7	≤10m	10~20m	> 20m
φ7.94	≤10m	10~20m	> 20m
φ9.52(recommended)	≤15m	15~25m	> 25m

AHU-KIT Installation

Do not install the AHU-KIT where electromagnetic wave is directly radiated to the control box or expansion valve box.

Do not install the AHU-KIT where generation, flowing, staying or leakage of flammable gas may occur. When the false ceiling contains high humidity, dew condensation water may occur on the outer surface of AHU-KIT. Therefore utilize the insulation on the outer surface of AHU-KIT.

CAUTION

- We suggest AHU-KIT be installed in the proper position on indoor side, Make sure the protection measures be done if AHU-KIT need to be installed on the outdoor side.
- The ambient temperature of AHU-KIT installation place should be under 60°C.

● Installation Location

1. The piping length between AHU and AHU-KIT should be designed no more than 5m, the level different between AHU and AHU-KIT should no more than 2m.
2. Check the ceiling slab is strong enough. If the ceiling slab is too weak to support the weight of AHU-KIT noise and vibration may occur.
3. Secure proper space around AHU-KIT for operation and maintenance work. Also a service access door should be prepared in order to remove the AHU-KIT without getting rid of the ceiling plate if it is installed on the false ceiling.
4. Select a suitable and convenient location for the refrigerant piping connection.
5. Do not install the AHU-KIT in a kitchen where vapor or mist flows.
6. The sound of refrigerant running through from the expansion valve may be heard. Therefore install AHU-KIT where the sound will not leak such as in the false ceiling of a hall way.
7. Use ceiling material with sound-proof such as plaster board.
8. Pipeline installation requirements between outdoor unit and AHU: the pipe diameter specification shall be strictly in accordance with the installation instructions of outdoor unit. If the length of main pipe is more than 90m, the specification of gas pipe and liquid pipe shall be increased by one.

● AHU-KIT Installation

1. Make sure the piping length between AHU and AHU-KIT no more than 5m (Supplied wire in the accessory box is 10m.)
2. Open the AHU-KIT cover by unscrewing the screws on the box.
3. Drill 4 holes on the correct position of the wall and fix the AHU-KIT securely. (Refer to the dimension data.)
4. Make sure that pipes are fully insulated. If there is any uninsulated part, it may cause condensation dripping.
5. AHU-KIT should be installed in the vertical direction within the range of $\pm 15^\circ$. If it is tilted over than 15° , it can badly affect normal operation of EEV.

Installation drawing

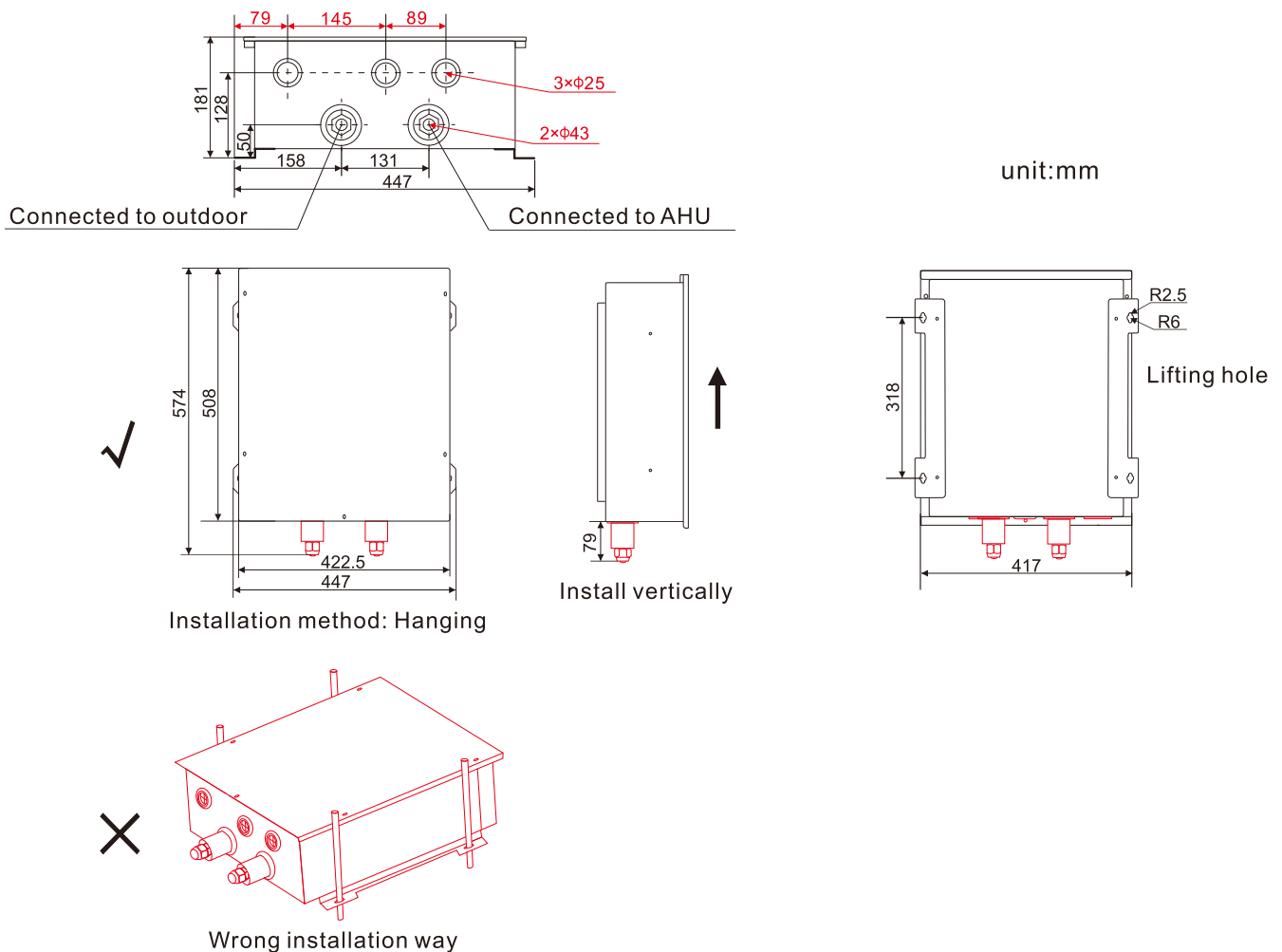

NOTES:

- 1.The AHU-KIT can not installed in outdoor occasions, if inevitable, it must increase rainproof precautions, specific methods please contact the local dealer or technical support engineer.
- 2.As hanging installation, the box should be vertical, and the box can not be installed horizontally.
- 3.This product does not provide hanging installation screws.
- 4.Please refer to the foregoing, make sure the lying direction of the refrigerant pipe and the connecting place of the connecting wire.

● Temperature Sensor Installation

There are three temperature sensors in the accessories, which must be installed in the correct position and connected to the main control board before power on.

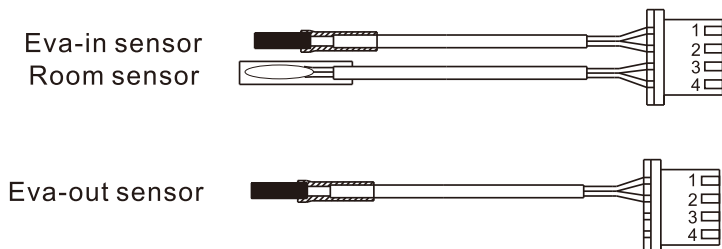

● Eva-in(liquid pipe) and Eva-out(gas pipe) temperature sensor

The purpose and identification of each one is as follow:

Item	Temperature sensor connector color	Copper sensor OD (mm)	Sensor holder ID (mm)	Wire length (m)
Liquid pipe	blue	φ 6	φ 7	10
Gas pipe	green	φ 6	φ 7	10

NOTE:

When fitting the liquid & gas temperature sensor, remember that they must be secured correctly by the special clamp, ensuring the perfect contact between the pipe and temperature sensor. Cover it completely with insulation, like cork tape or pipe insulation, depending on the location. Replace them if damaged during maintenance work.

•Typical installation location

1	Liquid pipe temperature sensor	Must be installed at the inlet pipe behind the liquid separation head of the evaporator and the lowest temperature path in the refrigeration direction (contact the dealer of the heat exchanger). The lowest path of the flow path of the heat exchanger is recommended.
2	Gas pipes temperature sensor	Must be installed within 200 mm behind the gas collecting pipe of the heat exchanger.

Gas & Liquid Temperature Sensor Location

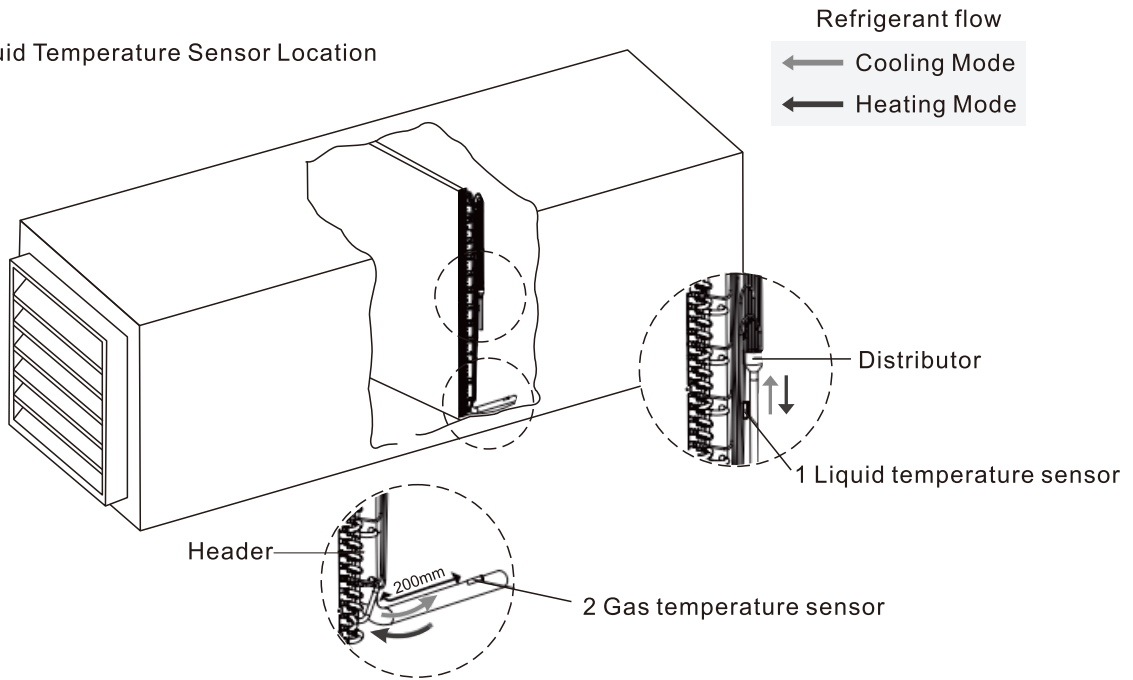

• Installation procedure

1. Braze the sensor holder (field supplied) at location suggested above and fix the sensor with sensor clip. Make sure that filter and valve body should be kept under 120°C with wet cloth when you braze the copper sensor holder. (If the distance between EEV location with the AHU is within 2 meters, you the use the Eva-in temperature sensor holder brazed in the EEV directly.)

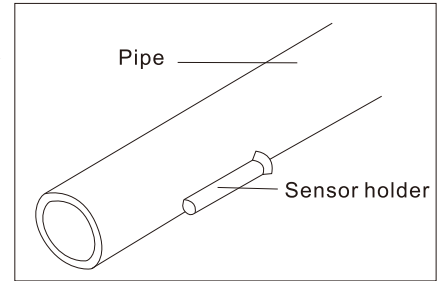

2. Insert sensor (factory supplied) and the sensor clip (field supplied) in the sensor holder;

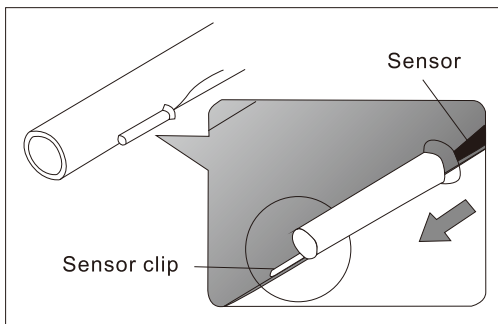

3. Bend end of the sensor clip to fix the sensor;

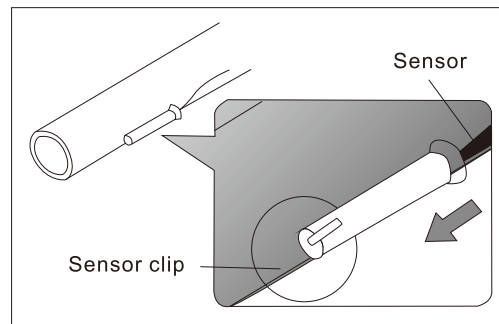

4. Attach the insulator (field supplied) around the sensor.

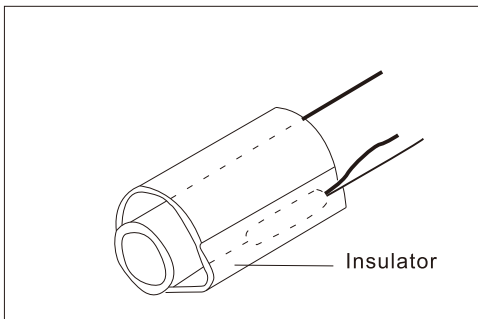

● Room temperature sensor

Room temperature sensor should be installed where room air enters.

• For partial fresh air system

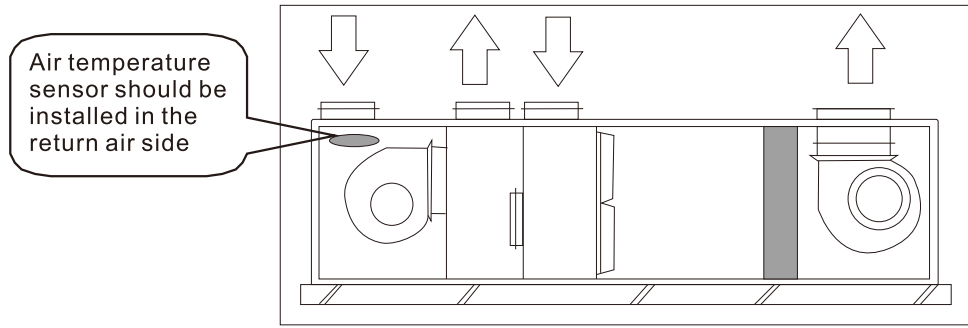

• For all fresh air system

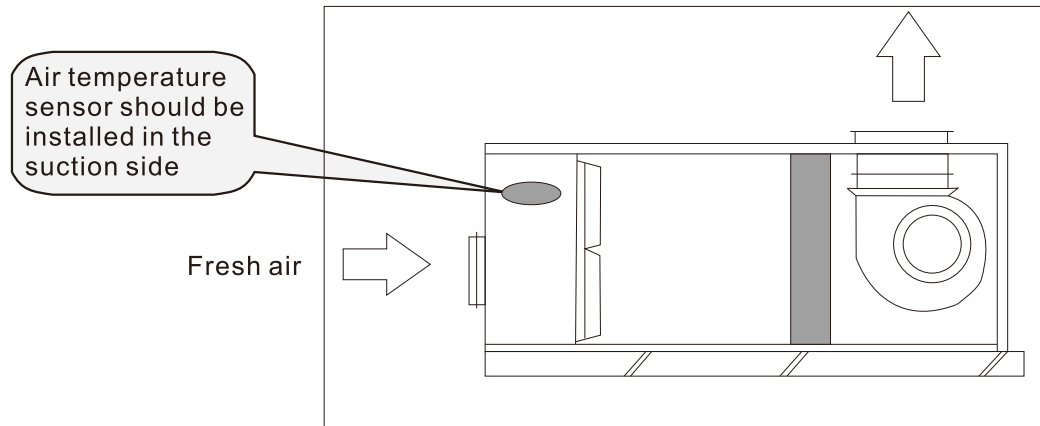

CAUTION

- 1.If two or more AHU-KITs are connected to one AHU in parallel, only the master AHU-KIT needs to connect Eva-in sensor, Room sensor, Eva-out sensor.
- 2.Securely fix the sensor and it should be protected from water submerged, dust accumulation, mechanical stress and other conditions that may have a influence on temperature acquisition or life span of sensor.

● Connection and Brazing of auxiliary pipe

• Requirement for flaring opening connection

1. Deburr the auxiliary pipe before flaring, then flare auxiliary pipe with flaring tool as per the dimensions of flaring opening in the following table.
2. Apply a thin layer of refrigeration oil on both inside and outside at the flaring part.
3. Align flaring opening with threaded joint of indoor unit, manually and tightly screw flared nut, then screw with torque wrench as per the tightening torque in the following table.
4. Remove valve cap on liquid valve and air valve of shut off valve of outdoor unit, align flaring opening with shut off valve of outdoor unit, sufficiently screw fared nut with hand, and then screw with torque wrench as per the tightening torque in the following table.

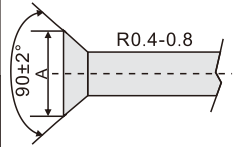
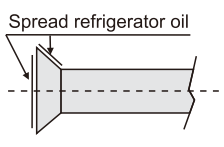
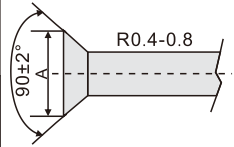
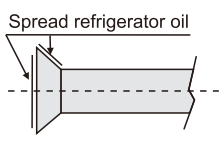
Model	Diameter of Auxiliary pipe	Tightening torque	Machining dimension of flared section(A)	Shape of flaring opening	Apply oil
ARVK-01A	1/2in(φ12.7mm)	50-60(N•m)	16.2-16.6mm		
ARVK-02A	5/8in(φ15.88mm)	60-65(N•m)	19.3-19.7mm		

5. Install the connection piping after the AHU-KIT and outdoor units have been fixed.
6. During the installation of connection piping, ensure no air, dust, or other sundries enter to the piping system.
7. The connecting copper pipes must be wrapped with thermal insulation materials (usually the thickness should be more than 10mm; in some humid area it should be thickened properly).

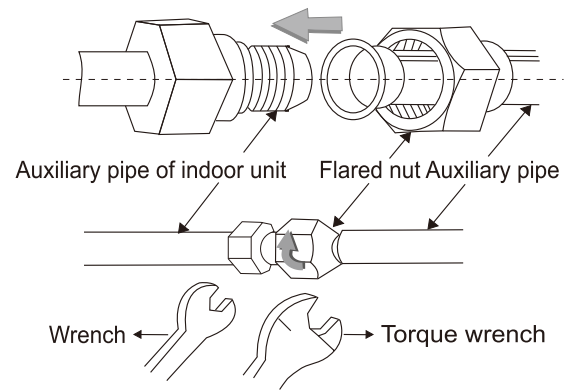

• Requirement of brazing the Pipe

- Make sure that there is no moisture inside the pipe.
- Make sure that there are no foreign materials and impurities in the pipe. Make sure that there is no leak.
- Be sure to follow the instruction when brazing the pipe.

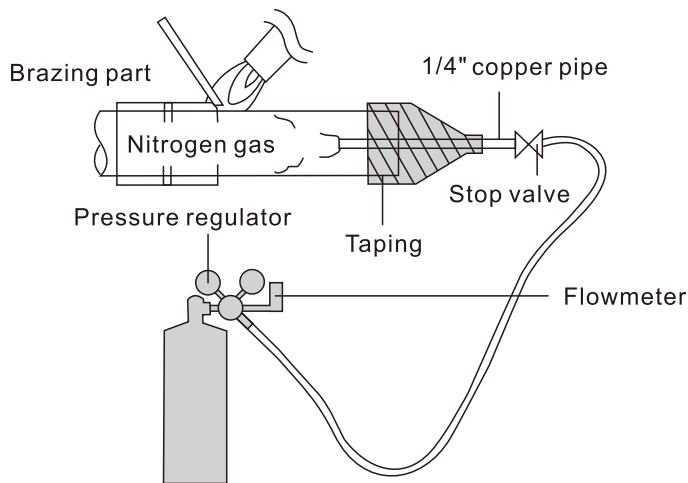

• The use of Nitrogen gas

Use Nitrogen gas when brazing the pipes as shown in the picture. If you do not use Nitrogen gas when brazing the pipes, oxide may form inside the pipe. It can cause the damage of the compressor, valves. Adjust the flow rate of the Nitrogen gas with a pressure regulator to maintain 0.05m³/h or less.

● Electrical wiring

CAUTION

1. The outdoor unit and the AHU-KIT should use separate power supply with rated voltage, but all the AHU-KIT and other AHU in the same system should be use the same power.
2. The external power supply to the air conditioner should have ground wiring, which is linked to the ground wiring of the AHU-KIT and outdoor unit.
3. The wiring work should be done by qualified persons according to circuit drawing.
4. The fixed connection wire must equip with at least 3mm electric shock spacing.
5. A leakage protector should be installed according to the local electrical standard.
6. Be sure to properly locate the power wiring and the signal wirings to avoid cross-disturbance and their contact with connection piping or stop valve. Generally, do not twist two wiring together unless the joint is soldered well and covered with insulator tape.
7. Do not turn on the power until the electrical wiring have been done correctly.
8. Maximum cable length and the amount of voltage drop for AHU power/communication cables should be under 10%.
9. Communication cable should be installed separately from power cable or other cables.

● Fan motor wiring

The AHU has only one AC motor control port.

Right figure shows it has three different wind speeds (high speed, medium speed, low speed).

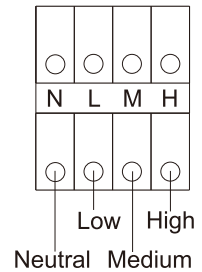

• Single fan speed AC motor

It is necessary to set SW1-4 to OFF position before connecting.

DIP switch and motor wiring reference as follows.

Note, the product do not include the contactor

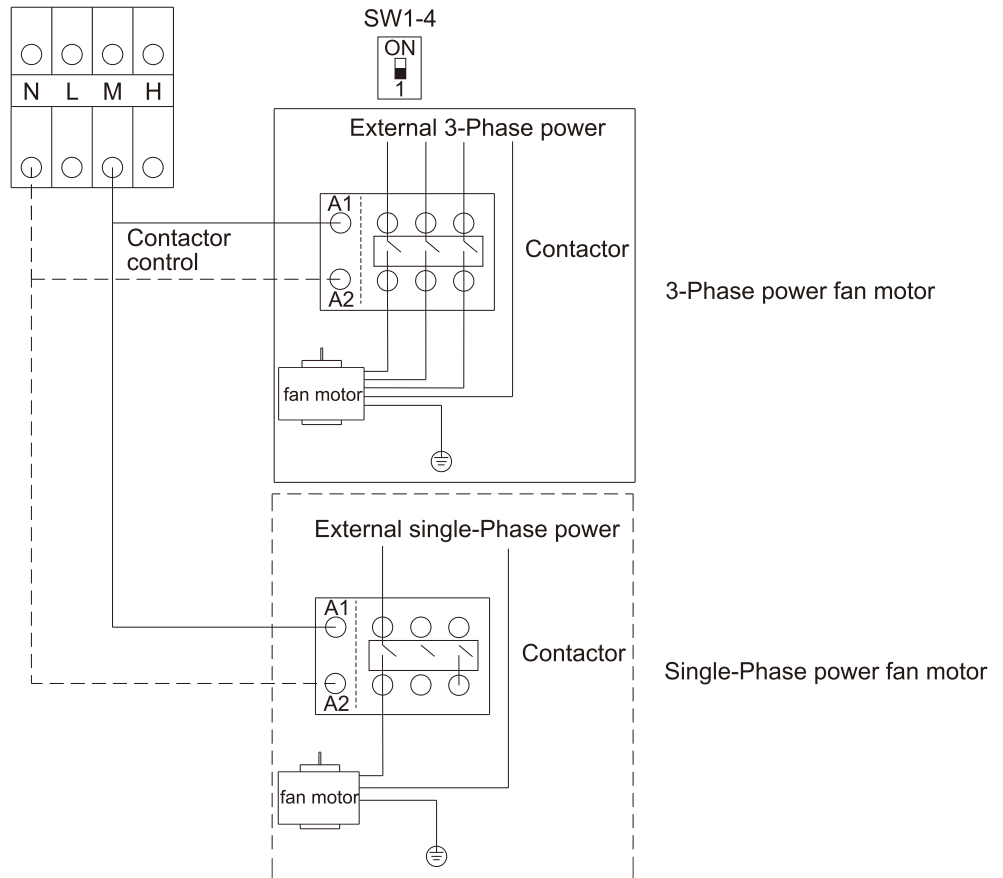

• Three fan speed AC motor

It is necessary to set SW1-4 to ON position before connecting.

DIP switch and motor wiring reference as follows.

Note, the product do not include the contactor

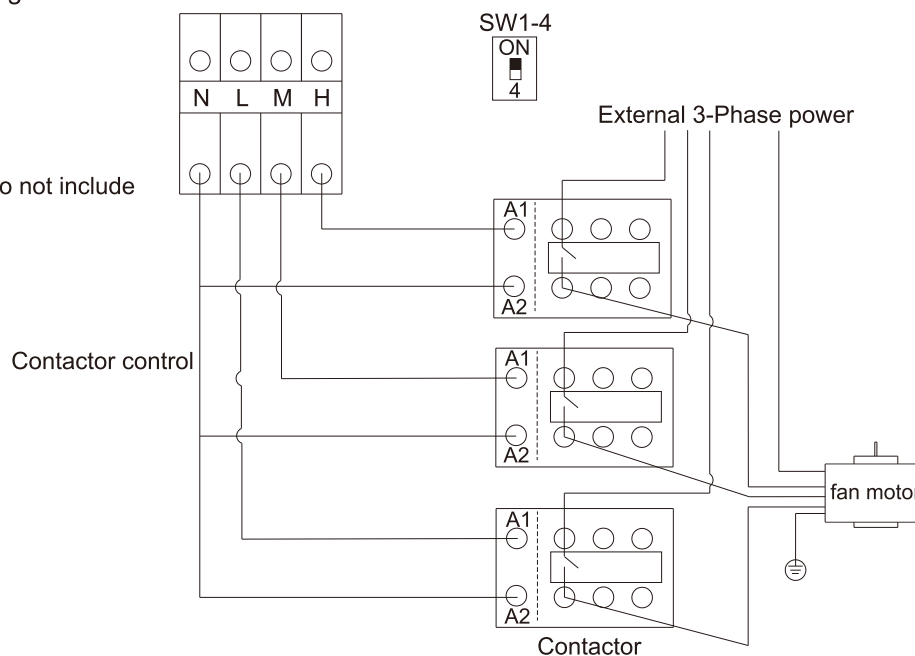

NOTE: the product do not include the contactor. Please get the AC contactor from local market.

• **Signal wiring**

Signal wiring is divided into wiring of master-slave AHU-KIT and wiring of controller.

➤ **Wiring of master-slave AHU-KIT**

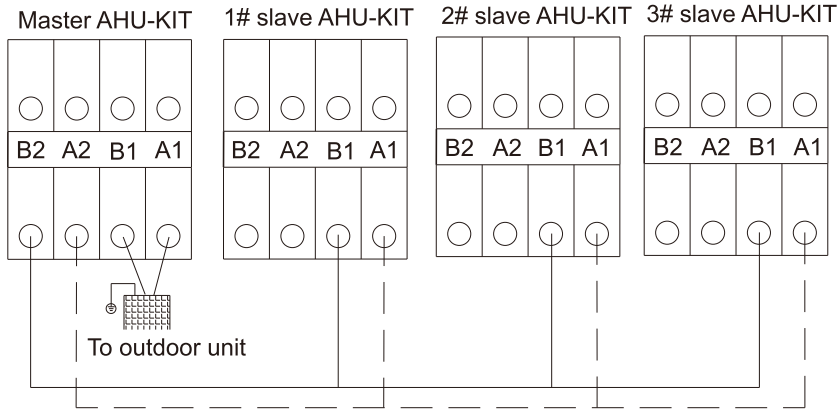

Please use 2-core shielding wire, and ground the shielding layer

➤ **Wiring of controller**

(1) **AUX wired controller**

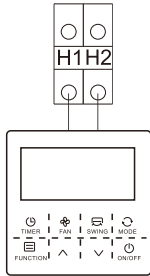

(2) **Third party controller (PLC/DDC)**

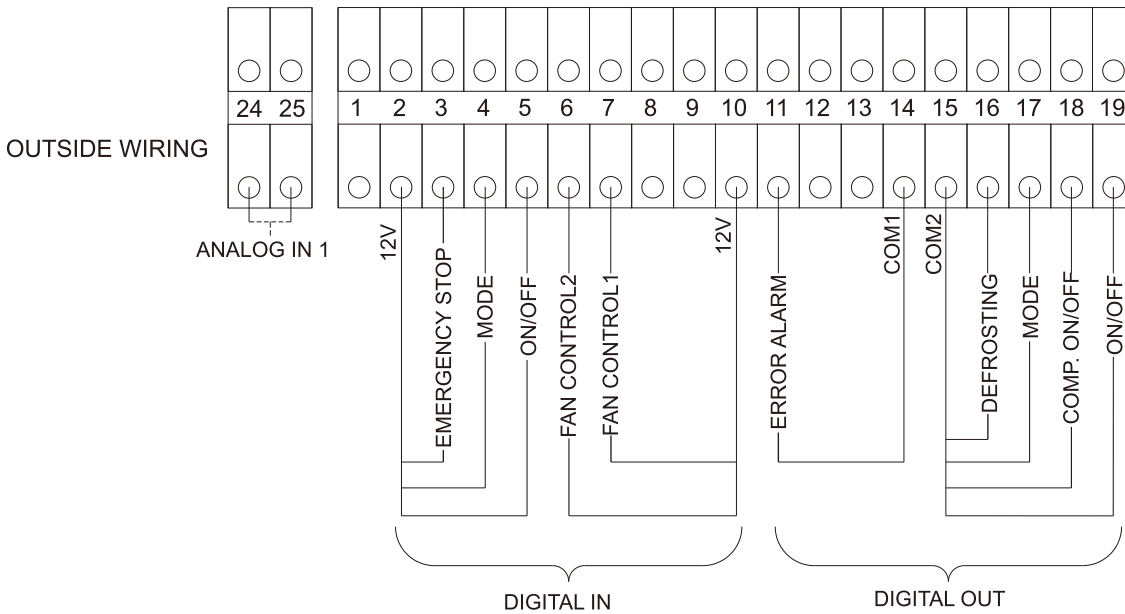

The communication ports with third party controller

(3) **Third party controller (MODBUS protocol)**

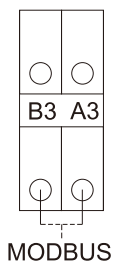

Example of signal wiring

Signal wire (A1、 B1)	The signal wire of master AHU-KIT between outdoor and master AHU-KIT The signal wire of slave AHU-KIT between master AHU-KIT and slave AHU-KIT
Signal wire(A2、 B2)	The signal wire of master AHU-KIT between master AHU-KIT and slave AHU-KIT The signal wire of slave AHU-KIT is unconnected

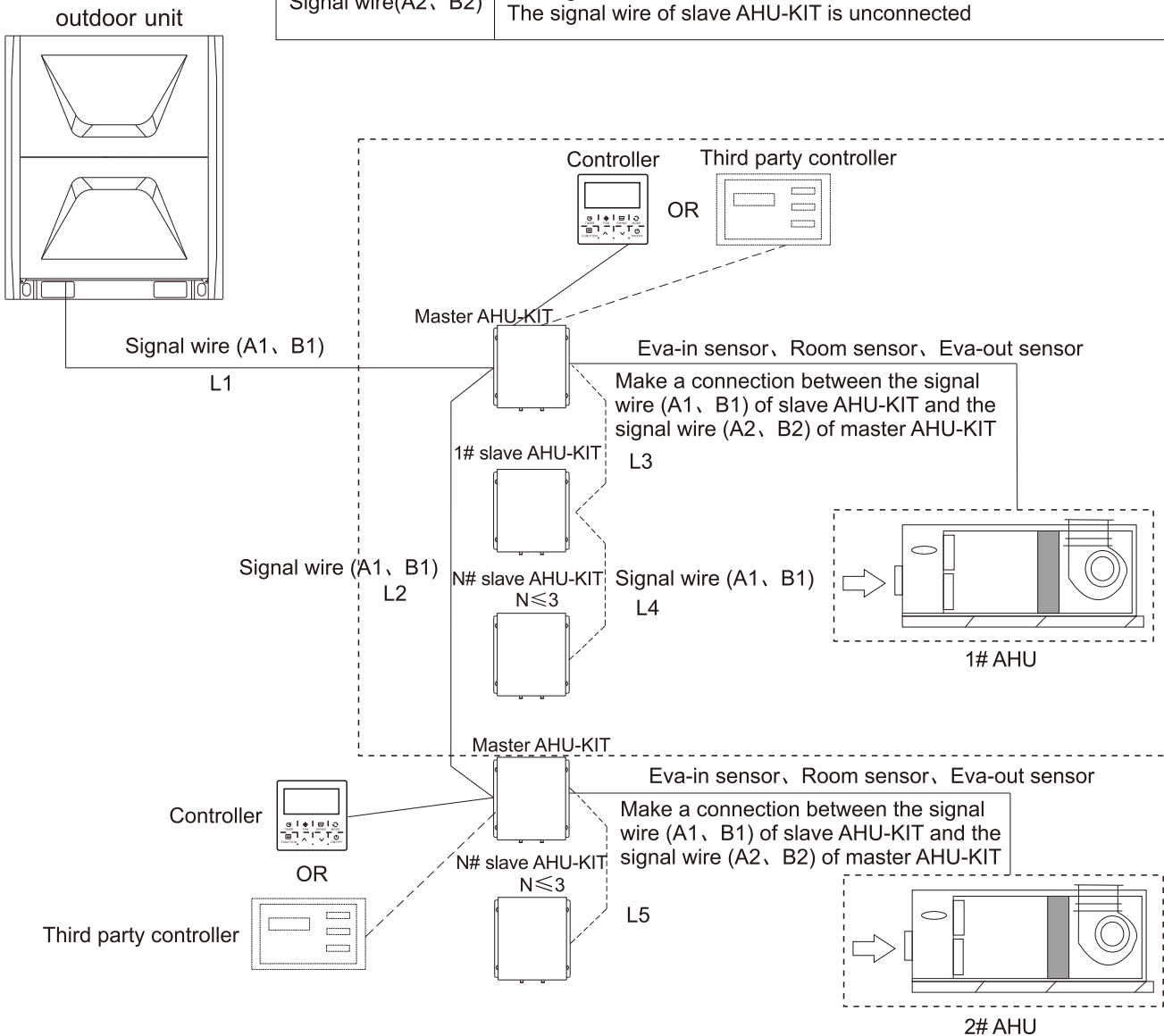

NOTES:

1. The diameter of signal wire should be greater or equal to 0.75mm², and the A1、 B1 and A2、 B2 signal wire should be 2-core shielding wire.
2. Maximum wiring length: L1+L2<1200m; L3+L4<1200m; L5<1200m.
3. Only when the wired controller is selected to control AHU-KIT (through DIP switch setting), then the system can receive the signal from wire controller.
4. When the third party controller is selected to control AHU-KIT(through DIP switch setting), then the system can receive the signal from third party controller.

• **Wring main power cables**

The terminal block for main power cables is shown as below.

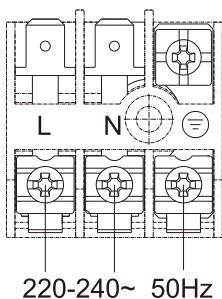

Schematic drawing of main power wiring

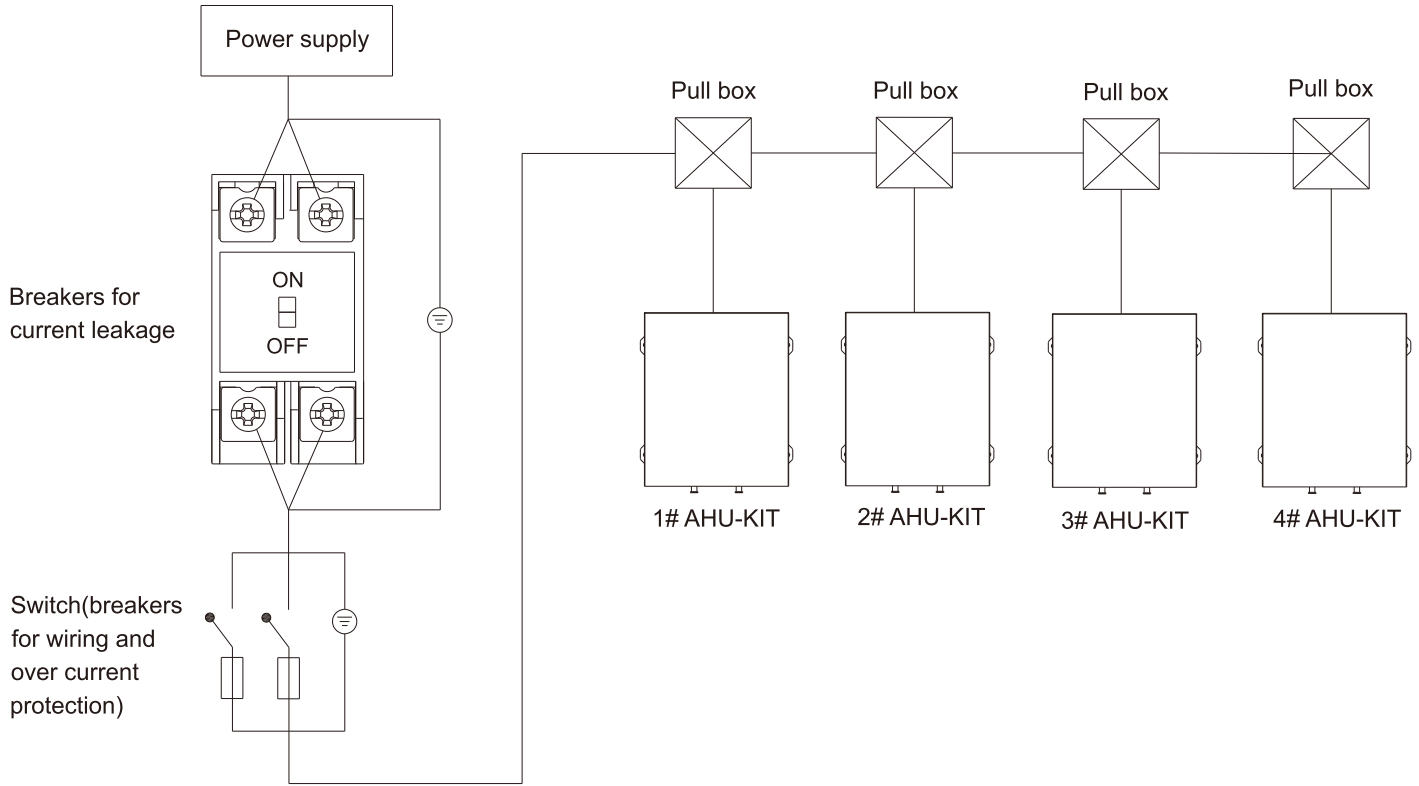

Thickness of main power cable

Please select main power cable refer to table

Model		ARVK-01A/ ARVK-02A
Power	Phase	Single-phase
	Voltage and Frequency	220-240V~50Hz
AHU-KIT power wire(mm ²)		3×1.5mm ²

CAUTION

1. Specific wiring requirements should adhere to the wiring regulations of the region.
2. Use only copper wires.
3. Be sure to use specified wires for connections and ensure no external force is imparted to terminal connections. If connections are not fixed firmly, heating or fire may result.
4. The wire size is the minimum value for metal conduit wiring. If the voltage drops, use a wire that is one rank thicker in diameter. Make sure the power-supply voltage does not drop more than 10%.
5. Power must unified supply to all AHU-KIT in the same system.
6. A breaker for current leakage must be attached to the power supply. If no earth leakage breaker is installed, it may cause an electric shock.
7. Do not use anything other than a breaker and fuse with the correct capacity. Using a fuse or wire of too large capacity may cause malfunction or fire.
8. Never connect the main power source to terminal block of communication line. If connected , electrical parts will burn out.

Definition Of Each Dial Switch

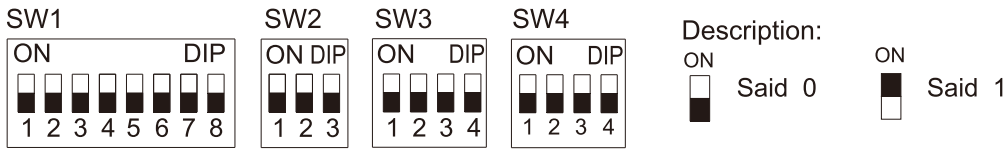

NOTE:

After changing the status of any dial switch on the main board, be sure to turn off the total power switch and then switch on. The setting function can not be carried out if not to turn off the total power switch and then switch on.

● SW1 Definition

NO.	SW1-1	SW1-2	SW1-3	SW1-4	SW1-5	SW1-6	SW1-7	SW1-8
Function	AI Control	Terminal control		Fan speed	Room temp. correction in heat mode		Anti-cold-air temperature	
Description	0:Temperature setting 1:Pressure setting	00:Wired controller 01:PLC/DDC 10:Modbus 11:Invalid		0:Single speed 1:Three speeds	00: 0°C 01:-1°C 10:-3°C 11:-4°C		Tao ≤ 10°C / > 10°C 00: 26°C / 30°C 01: 24°C / 28°C 10: 20°C / 24°C 11: 18°C / 22°C	

NOTES:

- SW1-1 AI control:0:Temperature setting 1:Pressure setting. AI control is effective when connected to a third-party controller.
- After the control terminal is set, the address of AHU-KIT needs to be set. After power on for the first time, please set the address of control box on AHU-KIT with remote controller or remote controller. All AHU-KIT addresses cannot be repeated (Reference wire controller).

● SW2 Definition

NO.	SW2-1	SW2-2	SW2-3
Function	Master/Slave	Quantity of slave kits(set on the master kit)	
Description	0:Master 1:Slave	00:0 01:1 10:2 11:3	

(1) Master /Slave AHU-KIT setting

In one refrigerant AHU system, it is necessary to set master/slave for each AHU-KIT. If only one AHU-KIT, then it should be set to Master (SW2-1 be set to OFF(0) position). If there are multi AHU-KITs, and there is a ARVK-02A model, then choose the ARVK-02A model to master (SW2-1 be set to OFF (0) position) , others are set to slave(SW2-1 be set to ON(1) position).

(2) Slave AHU-KIT quantity setting

SW2-2, SW2-3 be set to show the quantity of slave units. for example ,there are 2 slave units, then the SW2-2, SW2-3 on the master AHU-KIT should be set to ON OFF (10) position).

Note:SW2-2, SW2-3 only valid on master AHU-KIT.

● **SW3 Definition**

NO.	SW3-1	SW3-2	SW3-3	SW3-4	Describe
1	0	0	0	0	Factory defaults
2	0	0	0	1	4HP
3	0	0	1	0	6HP
4	0	0	1	1	8HP
5	0	1	0	0	10HP
6	0	1	0	1	12HP
7	0	1	1	0	14HP
8	0	1	1	1	16HP
9	1	0	0	0	18HP
10	1	0	0	1	20HP
11	1	0	1	0	22HP
12	1	0	1	1	Reserved
13	1	1	0	0	
14	1	1	0	1	
15	1	1	1	0	
16	1	1	1	1	

1. ARVK-01A factory default capacity is 10HP; ARVK-02A factory default capacity is 20HP.

2. The way to set the capability:

First, SW1-2 and SW1-3 be set to [01], it means [PLC/DDC] mode, then change SW3 setting to match the AHU capacity.

NOTES:

1. After SW3 be set, AHU-KIT should be re-power;

2. After re-power, if the third part controller be connected to KIT PCB, then SW1-2 and SW1-3 no need to change;

3. After re-power, if the wired controller be connected to KIT PCB, then SW1-2 and SW1-3 should be changed to [00].

Controller Selection

AHU-KIT can be controlled by wire controller or third party controller, and the third party controller can support PLC / DDC terminal or Modbus protocol terminal. The status of SW1-2 and SW1-3 on the main PCB of AHU-KIT determines which control terminal is selected.

SW1-2/SW1-3



means to connect wired controller



means to connect third party controller(PLC/DDC)

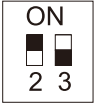

means to connect third party controller(Modbus)

NOTE:

After changing the status of any dial switch on the main PCB, be sure to turn off the total power switch and then switch on. The setting function can not be carried out if not to turn off the total power switch and then switch on.

● Wire controller

- When the wired controller mode is selected, the AHU-KIT must be connected to the wired controller to operate.
- Please refer to the operation manual for details of the wire controller.
- Note that the main PCB of AHU-KIT will not respond to signals from third party controllers when wire controller is selected.

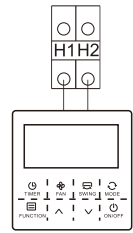

Parameter query:

1. Press and hold the [function] key for 5 seconds to enter the AHU-KIT parameter query interface.
2. The upper part of the display screen shows [parameter number and parameter value], for example, the display screen shows [0303].
The first parameter [03] is the parameter serial number, and the second [03] is the corresponding parameter value.
3. After entering the parameter query interface of the indoor unit, the parameter query of the indoor unit can be realized by using the “^” or “v” key.
4. After 10 seconds without any key operation, or by pressing the “^” or “v” key or any key other than the function key, the query mode will exit.

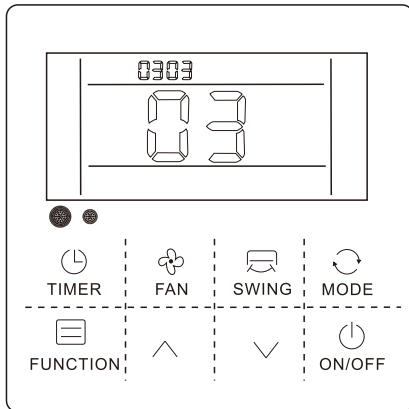

IP address setting:

1. Press and hold the [function] key for 5 seconds to enter the AHU-KIT parameter setting interface.
2. Adjust the [parameter number] through the key “^” or “v” to the address modification interface, that is, adjust the display of the top two digits of the display [01].
3. Press and hold the [function] key for 5 seconds to enter the [parameter value] setting interface, and adjust the top two digits of the display through the “^” or “v” key coordination.
4. After modifying the parameters, press the “function” key to modify the parameters(if there is no operation after 10 seconds, the modification fails). Parameter query will be automatically returned if parameter modification is effective or failed.

NOTE: that the IP address of each AHU-KIT must be different.

● Third party controller

- Third party controller can support PLC / DDC terminal or Modbus protocol terminal.
- When third party controller has been selected, only third party controller can be use to control the AHU-KIT.
- Even if third party controller has been selected, a wired controller is need to set address for each AHU-KIT, because third party controller do not have this function.

NOTES:

- 1.Third party controller should be purchased from market.
- 2.The distance between third party controller and AHU-KIT should be less than or equal 15m.
- 3.If several AHU-KIT parallel connection control one AHU, third party controller only need to be connected with master AHU-KIT.

● Temperature setting and pressure setting

The third party controller has two control modes: temperature setting and pressure setting (Table C and Table D for control contents).

SW1-1



means to temperature setting



means to pressure setting

NOTE: in pressure setting mode, a third party controller can not control two or more AHU at the same time.

● PLC/DDC terminal

All signals between the third party controller PLC / DDC terminal and AHU-KIT must comply with the definitions in Table A and Table B. If the signal definition in the third party controller does not conform to this manual, it will not work normally.

● The signal between PLC / DDC terminal and AHU-KIT is defined as follows (Wiring diagram is shown in third party controller (PLC/DDC)).

1.Signal from the third party controller to AHU-KIT

Table A

NO.	Signal	Signal type	Specification	Port
1	Temperature setting or pressure setting	Analog voltage	0-10VDC Please refer to table.9-3 and 9-4	24-25
2	Emergency stop	Dry contact	close: OFF and do not allow shutdown disconnect: allow power on	2-3
3	On/OFF	Dry contact	close: ON disconnect: OFF	2-5
4	Cool or heat mode	Dry contact	close: heat mode disconnect: cool mode	2-4
5	Fan control 1	Dry contact	1 and 2 are disconnected: low fan speed 1 is disconnected, 2 is closed: mid fan speed 1 is closed, 2 is disconnected: high fan speed 1 and 2 are closed: Auto fan	7-10
6	Fan control 2	Dry contact		6-10

NOTE: the analog voltage must be between maximum and minimum value.

2.Signal from AHU-KIT to the third party controller

Table B

NO.	Signal	Signal type	Specification	Port
1	Error alarm	Dry contact	close: alarm disconnected: no alarm	11-14
2	Defrost	Dry contact	close: defrosting disconnected: no defrost	15-16
3	Cool or heat mode	Dry contact	close: heat mode disconnected: cool mode	15-17
4	Comp. ON/OFF	Dry contact	close: comp. ON disconnected: comp. OFF	15-18
5	Run status	Dry contact	close: running disconnected: off	15-19

3. Temperature and pressure values corresponding to different Analog voltages.

Table C

Analog input 0-10V		Temperature setting (°C) Cooling	Temperature setting (°C) Heating
Voltage range (V)	Normal (V)		
[0.00, 0.60]	0	16	16
[0.60, 1.20]	0.9	17	17
[1.20, 1.80]	1.5	18	18
[1.80, 2.40]	2.1	19	19
[2.40, 3.00]	2.7	20	20
[3.00, 3.60]	3.3	21	21
[3.60, 4.20]	3.9	22	22
[4.20, 4.80]	4.5	23	23
[4.80, 5.40]	5.1	24	24
[5.40, 6.00]	5.7	25	25
[6.00, 6.60]	6.3	26	26
[6.60, 7.20]	6.9	27	27
[7.20, 7.80]	7.5	28	28
[7.80, 8.40]	8.1	29	29
[8.40, 9.00]	8.7	30	30
[9.00, 9.60]	9.3	31	31
[9.60, 10.00]	10	32	32

Table D

Analog input 0-10V		Capacity of units(%)	Target low pressure(kPa) / temperature(°C)	Target high pressure(kPa) / temperature(°C)
Voltage range(V)	Normal (V)			
[0.00, 0.50]	0.00	/	OFF	OFF
[0.50, 1.50]	1.00	40	1162(15)	1895(32)
[1.50, 2.50]	2.00	45	1091(13)	2052(35)
[2.50, 3.50]	3.00	50	1024(11)	2218(38)
[3.50, 4.50]	4.00	60	959(9)	2394(41)
[4.50, 5.50]	5.00	70	898(7)	2579(44)
[5.50, 6.50]	6.00	80	839(5)	2775(47)
[6.50, 7.50]	7.00	90	810(4)	2911(49)
[7.50, 8.50]	8.00	100	755(2)	3053(51)
[8.50, 9.50]	9.00	100	755(2)	3053(51)
[9.50, 10.0]	10.00	100	755(2)	3053(51)

NOTE:

The analog input must be set with a normal value, and the actual analog input must be between the maximum voltage and the minimum voltage.

0-10V capacity output setting valid for the refrigerant system which only connect to one AHU, ODU should be ARV6 series.

● **Operation instruction**

After the third party controller PLC / DDC terminal is selected, the AHU-KIT will operate according to the control signal of the third-party controller, and output alarm, defrosting, mode, machine on / off and press status signals.

● **Modbus protocol terminal (Wiring diagram is shown in third party controller (MODBUS protocol)).**

➤ Modbus protocol settings

Setting parameters	Parameter
Baud Rate	9600
Data bits	8
Stop bits	1
Parity check bit	Even check
Address unit setting	1~247
Support MODBUS function code	03,06,16
Support or un-support broadcasting	Support

➤ Holding registers data sheet

Address	content	Access type (W/R)	Definition	Unit	Type
0	ON/OFF setting	W/R	0-OFF, 1-ON, 2: no present or found	/	Signed Word
1	Compressor status	R	0: running, 1: stop	/	Signed Word
2	Run mode	W/R	0: Auto, 1: Cooling, 2: Dry, 4: Heating, 6: Fan	/	Signed Word
3	Temperature setting or Pressure setting	W/R	Temperature setting: [16, 32] Pressure setting: [0, 10] (pressure does not return unit data, only current control data)	0.1°C/1V	Signed Word
4	Setting fan speed	W/R	1: High, 2: Medium, 3: Low, 5: Auto	/	Signed Word
5	Reserve	R		/	Signed Word
6	Present error code	R	[0, 255]. Eg: 0xA1 means A1 error code	/	Signed Word
7	Room temperature	R		0.1°C	Signed Word
8	Inlet coil temperature	R		0.1°C	Signed Word
9	Mid coil temperature	R		0.1°C	Signed Word
10	Outlet coil temperature	R		0.1°C	Signed Word
11	Defrosting state	R	0: no defrost, 1: defrosting		Signed Word
12-19	Reserve	R			Signed Word

Trouble Shooting

NO.	Error code	Definition	Cause of error	Solutions
1	A1	Room temperature sensor error	It may be that the plug has poor contact with the electric control board or the sensor is damaged	Reinsert the plug or replace the temperature sensor. After solving the problem, power off and power on to restart
2	A3	Inlet coil temperature sensor error		
3	A4	Outlet coil temperature sensor error		
4	A9	Communication error between AHU-KIT and outdoor unit	It is may that the communication connection between the master AHU-KIT and the outdoor unit is wrong or the contact is poor	Check the communication line connection between the master AHU-KIT and the outdoor unit, or whether the circuit is open
5	AA	Communication error between main PCB and wire controller or between main PCB and expansion PCB	It is may that the communication connection is wrong or the contact is poor	Check the communication line connection, or whether the circuit is open
6	AE	Different mode error	The operation mode of AHU-KIT is different in the system	Check that all AHU-KIT modes must be the same
7	AH	AHU-KIT address conflict	It is may that AHU-KIT has the same address	Manually address again to ensure that the address of each AHU-KIT is different. After setting, power off and restart
8	AJ	Anti-cold-air temperature	/	It is normal protection to prevent the temperature of the pipe from being too low
9	91	No master error	It is may that there is no master in the system	Check the dialing switch of the master AHU-KIT or the wiring error of the communication line between the master and the outdoor unit, and then power off and power on to restart
10	92	Error in setting the number of slave machines	The number of slave dialed by the master is inconsistent with the actual number of slaves	Check the number of the slaves on the master, dial the code and the actual number of slaves, and power off and restart after solving the problem

DE-COMMISSIONING, DISMANTLING & DISPOSAL

This product contains refrigerant under pressure, rotating parts, and electrical connections which may be a danger & cause injury. All work must only be carried out by competent persons using suitable protective clothing and safety precautions.



Read the Manual



Risk of Electric Shock

RoHS



Unit is Remotely controlled
& may start without warning



1. Isolate all sources of electrical supply to the unit including any control system supplies switched by the unit. Ensure that all points of electrical and gas isolation are secured in the OFF position. The supply cables and gas pipe work may then be disconnected and removed. For points of connection refer to unit installation instructions.
2. Remove all refrigerant from each system of the unit into a suitable container using a refrigerant reclaim or recovery unit. This refrigerant may then be reused, if appropriate, or returned to the manufacturer for disposal. Under NO circumstances should refrigerant be vented to atmosphere. Where appropriate, drain the refrigerant oil from each system into a suitable container and dispose of according to local laws and regulations governing disposal of oily wastes.
3. Packaged units can generally be removed in one piece after disconnection as above. Any fixing down bolts should be removed and then unit lifted from position using the points provided and equipment of adequate lifting capacity. Reference MUST be made to the unit installation instructions for unit weight and correct methods of lifting. Note that any residual or spilt refrigerant oil should be mopped up and disposed of as described above.
4. After removal from position the unit parts may be disposed of according to local laws and regulations.
5. Meaning of crossed Out wheeled dustbin: Do not dispose of electrical appliances as unsorted municipal waste, use separate collection facilities. Contact your local government for information regarding the collection systems available. If electrical appliances are disposed of in landfills or dumps, hazardous substances can leak into the groundwater and get into the food chain, damaging your health and well being. When replacing old appliances with new ones, the retailer is legally obligated to take back your old appliance for disposals at least free of charge.



Ningbo AUX Electric Co., Ltd.

1166 Mingguang North Road, Jiangshan Yinzhou District, Ningbo,
315191 Zhejiang, China

16437005000654