



# **Installation & Operation Manual**

## **for DC Inverter VRF Outdoor Unit**

- For your convenience, please read this statement carefully, in accordance with the specification steps.
- Please safely keep this manual for inspection.



## Safety Precaution

Incorrect operation due to ignoring instruction will cause harm or damage. The seriousness is classified by the following indications:

### WARNING

This symbol indicates the possibility of death or serious injury.

### CAUTION

This symbol indicates the possibility of injury or damage to properties only.

## WARNING

**This appliance can be used by children aged from 8 years and above and persons with reduced physical, sensory or mental capabilities or lack of experience and knowledge if they have been given supervision or instruction concerning use of the appliance in a safe way and understand the hazards involved. Children shall not play with the appliance. Cleaning and user maintenance shall not be made by children without supervision.(Only for the AC with CE-MARKING)**

**This appliance is not intended for use by persons (including children) with reduced physical, sensory or mental capabilities, or lack of experience and knowledge, unless they have been given supervision or instruction concerning use of the appliance by a person responsible for their safety. Children should be supervised to ensure that they do not play with the appliance. (Except for the AC with CE-MARKING)**



**The air conditioner must be grounded. Incomplete grounding may result in electric shocks. Do not connect the earth wire to the gas pipeline, water pipeline, lightning rod, or telephone earth wire.**

**Don't pull out the power plug during operating or with wet hands.**  
It can cause electric shock or fire.



**The appliance shall be installed in accordance with national wiring regulations.**

**Don't pull the power cord when pull out the power plug.**  
The damage of pulling power cord will cause serious electric shock.



**The power plug must be inserted tightly.**  
Otherwise, it can cause electric shock or overheating, even fire.



**Don't share the socket with other electric appliance, and use the broken or unstandord cord.**  
Otherwise, it can cause electric shock even fire.



**Clean the dust on the plug regularly.**  
Otherwise the dust mixed, humidity will result in insulation fault even fire.



An earth leakage breaker with rated capacity must be installed to avoid possible electric shocks.



Cut off the main power switch when notusing the unit for a long time. Otherwise, it may cause product failure or fire.

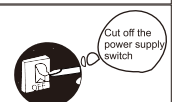

## WARNING

Stop operation and cut off the main power in storm or hurricane. Operation with windows opened may cause electric shock.



**Don't install air conditioner in a place where there is flammable gas or liquid. The distance between them should above 1m.**  
It may cause fire.



**Don't put a finger, a rod or other object into the air outlet or inlet.**  
As a fan is rotating at a high speed, it will cause injury.

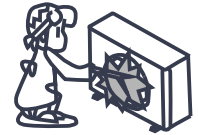

**Don't touch the swinging wind vanes.**  
It may clamp your finger and damage the driving parts of the wind vanes.

**Don't attempt to repair the air conditioner by yourself.**  
You may be hurt or cause further malfunctions.

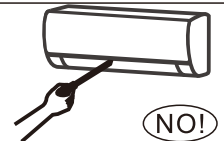

Take care not let the remote control and the indoor unit watered or being too wet, or may short circuit even caused fire.



Don't use liquid or corrosive cleaning agent wipe the air-conditioner and sprinkle water or other liquid either. Otherwise the inclosure will be damaged even electric shock.

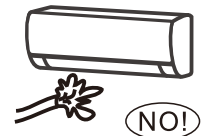

If the power supply cord is damaged, it must be replaced by the manufacture or its service agent or a similar qualified person.

- The refrigerant R410A leakage contributes to climate change. Refrigerant with lower global warming potential (GWP) would contribute less to global warming than a refrigerant with higher GWP, if leaked to the atmosphere. This appliance contains a refrigerant fluid with a GWP equal to [2088]. This means that if 1 kg of this refrigerant fluid would be leaked to the atmosphere, the impact on global warming would be [2088] times higher than 1 kg of CO<sub>2</sub>, over a period of 100 years. Never try to interfere with the refrigerant circuit yourself or disassemble the product yourself and always ask a professional.

## WEEE Warning

Meaning of crossed out wheeled dustbin:

Do not dispose of electrical appliances as unsorted municipal waste, use separate collection facilities.

Contact you local government for information regarding the collection systems available.

If electrical appliances are disposed of in landfills or dumps, hazardous substances can leak into the groundwater and get into the food chain, damaging your health and well-being.

When replacing old appliances with new ones, the retailer is legally obligated to take back your old appliance for disposals at least free of charge.



## Operation and Performance

---

### three-minutes protection

It should take about three minutes to re-start the unit after stop running or re-run the unit with manual switch. This is the self-protection of the compressor.

### Cooling & Heating

1. Indoor unit of DC inverter scroll central air-conditioning can be individually controlled, but the same system's outdoor unit can't be cooling or heating at the same time.
2. When it has conflict between cooling and heating type, mainly considered that mode which is operating at present, the other contrary mode make panel flashing, one indoor unit stop running, the other working indoor AC keep running as usual.
3. When the air conditioning fixed set by the administrators of cooling or heating is running, running outside cannot be set. Set outside of the operation, operation panel display "non-priority" or "standby" in the corresponding code, stop running.

### Heating Characteristics

1. Operation will not be immediately at the start of hot air blowing, after around 3~5 minutes(Delay or forward according to the temperature around) it will blowing hot air when indoor heat exchanger be heat enough.
2. During the air supply operation, if the other indoor units on a heating model, it is possible to suspend air supply in order to prevent hot air blowing.

### Defrost in Heating Mode

1. On heating model, outdoor machines occur the frost phenomenon, in order to improve the heating effect, automatic running defrost operation (about 2~10 minutes), the drainage vent from the outdoor unit.
2. On the defrosting mode, the outdoor fan motor stop running, indoor units without auxiliary heating stop the fan motor running, otherwise, indoor units running accordance with one minute period on-off interval.

### Heating Capacity

1. The system is absorbing heat from the outside, and releasing them to the indoor, once the outdoor temperature become lower, then the heating capacity will be lower.
2. Proposed use other heating equipments together when outdoor temperature is too low.
3. In the alpine areas where has a particularly low temperature, the heating effect will be even better if the indoor unit has auxiliary electric heating device.(Please read the detailed from Indoor Unit Manual)

### Protection Device (High Voltage Switch)

This device terminate running automatically during a compulsory working. Protection device moves circumstances, stop running, and show the trouble code. In the event of the following circumstances, the protection of installations is activated.

Cooling: Outdoor unit's inlet or outlet was full of plug. Sustained strong winds blow to the outdoor unit's tuyere.

Heating: Indoor unit's filter conglutinate too much excessive dust and litter. Indoor unit's outlet has been obturated.

#### NOTE:

**When protection device actions, please manually cut off the power switch, do not restart it till founded the reasons.**

# Outdoor Unit Installation

## Note:

- Installation professionals commissioned. Others possible to install the installation imperfections, which led to the leakage, electric shock or a fire officer.
- Avoid direct sunlight or other heat source, and if necessary a sun shelter should be mounted.
- The sites must be provide bearing surface level and enough firm to support the weight of outdoor unit.
- Install the unit is firm, otherwise it will caused abnormal noise and vibration by bad installation.
- The installation location must ensure air discharge and operation noise of unit can't disturb neighbors.
- Installation location to avoid fire hazard caused by flammable gas leakage.
- As far as possible move to a nearby obstacles, in order to prevent air circulation scope is too small and affect the unit performance.
- Meet the requirements of installation, try to install near the location of the indoor unit.
- Installation or high winds in the seaside, in order to ensure the normal operation of the fan, want to rely on outdoor wall installation, please use the panel if necessary.
- In strong wind areas, to prevent the wind blow, blow into the outdoor.
- Hang a wall to install is prohibited.

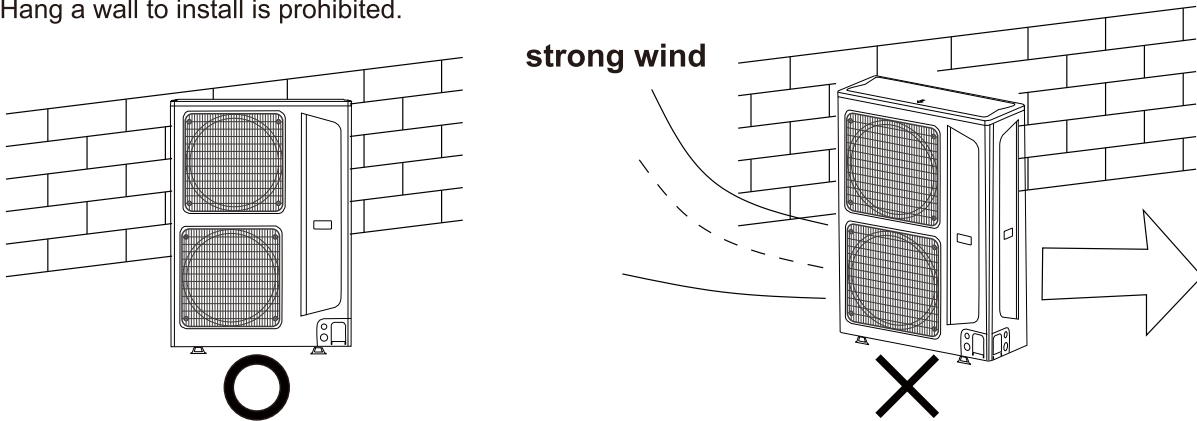

## Installation Space

Space required for installation and maintenance, as following figure.

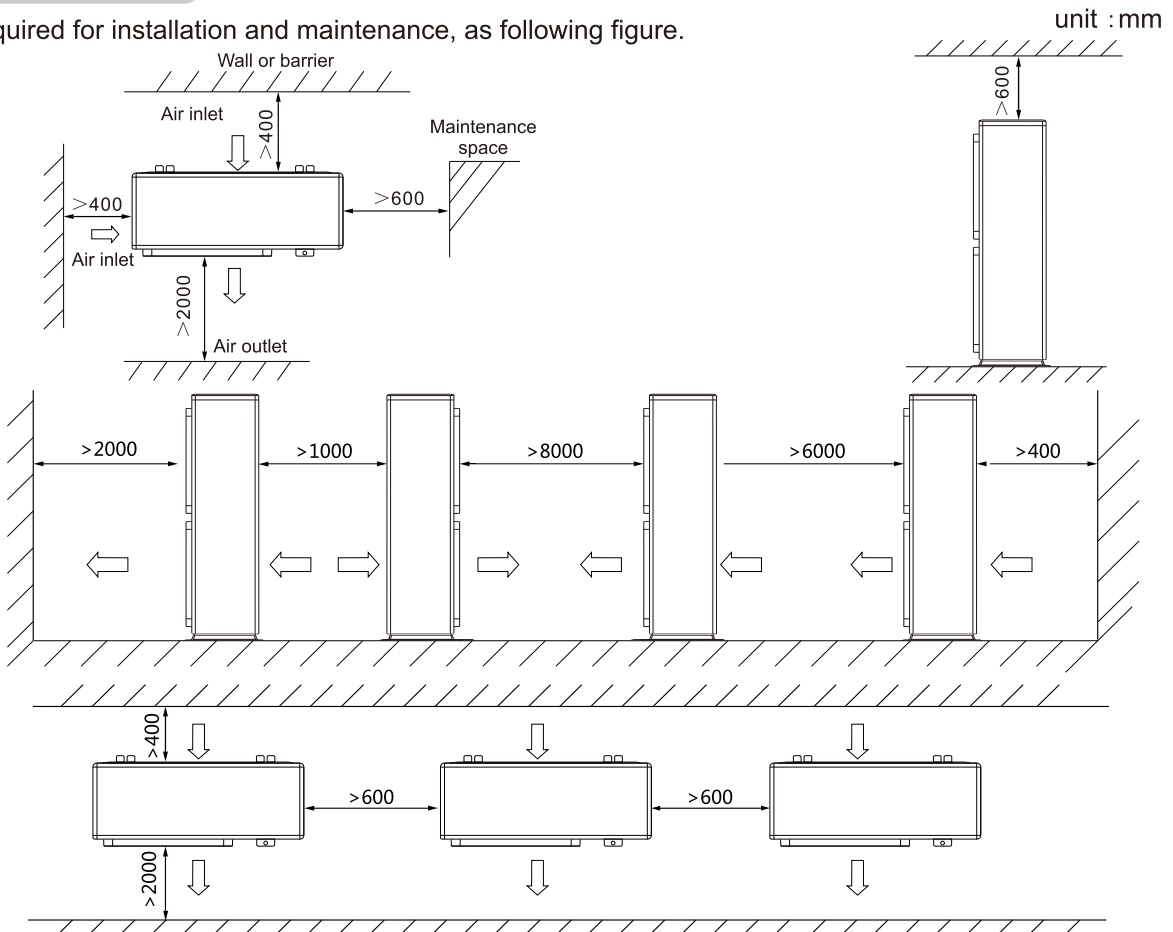

## Outdoor unit lifting

1. With more than 8 m two rope lifting in packing condition, keep the balance of the unit, safety steadily rising. In the absence of packaging or packaging damaged handling application plate or packaging for protection.
2. Lifting outdoor unit take care of the barycenter, in case of sliding and dumping. Unit the center of gravity is not in the center, should not be greater than 30°, and pay attention to safety in the process of handling, hoisting. As figure.
3. Please do not hold the shell of the wind net, otherwise it will make its deformation.
4. Please note that don't make the hand or other objects in contact with the rotor blades.
5. Don't lean over 45 degrees carrying, don't lie.

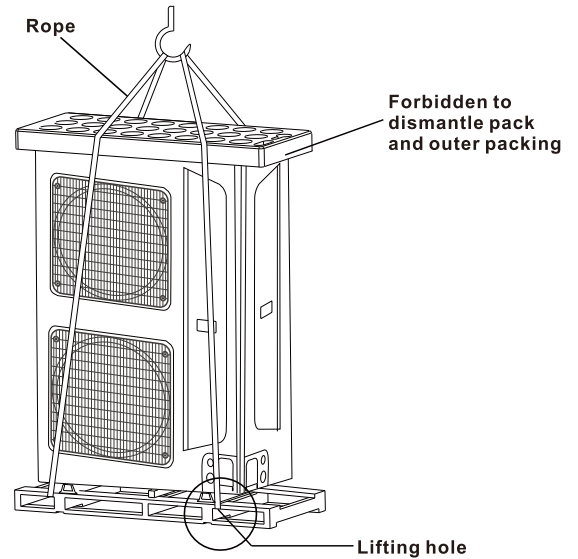

## Outdoor unit foundation

1. The foundation can be made of channel steel or concrete. Reserve the space for discharging the condensate water from outdoor units.
2. Try not to use four-square base to support outdoor unit; rubber anti-vibration pads are necessary to avoid vibration.

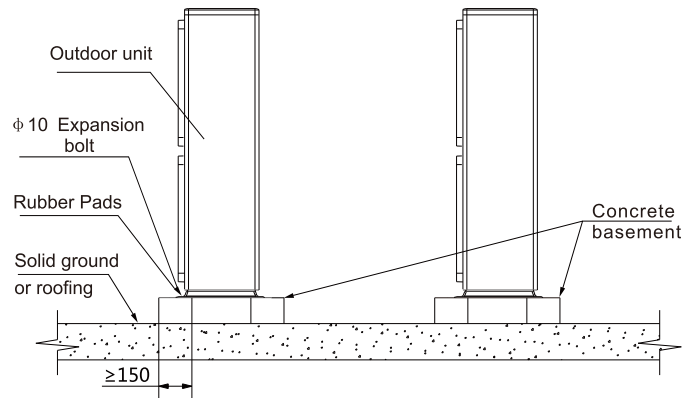

## Dimension size

unit: mm

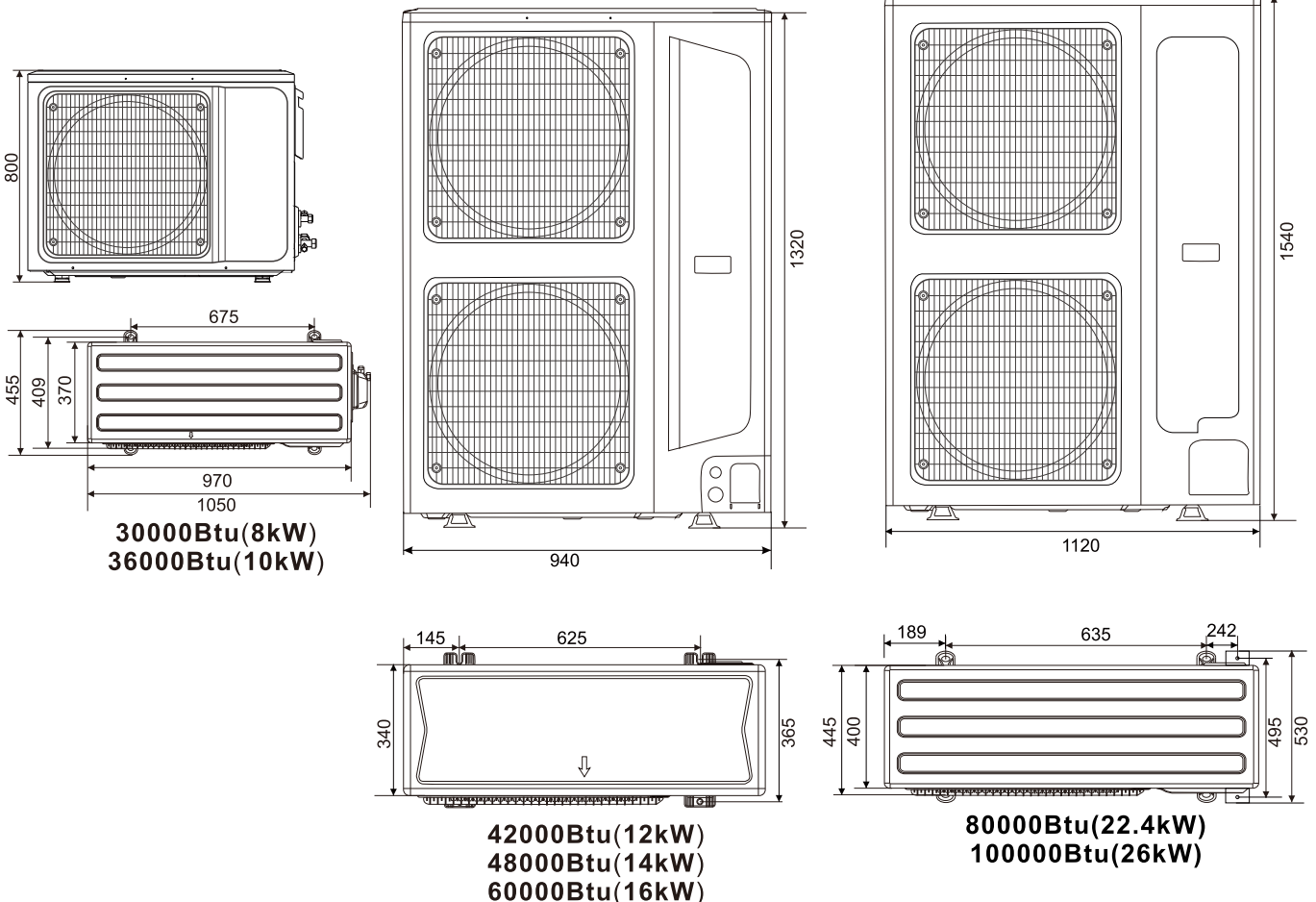

# Connecting Pipe Installation

## Refrigerant piping

### 1. Flaring

- With the pipe cutting knife to cut off the pipe .
- Connect the pipe sleeve nut flaring .

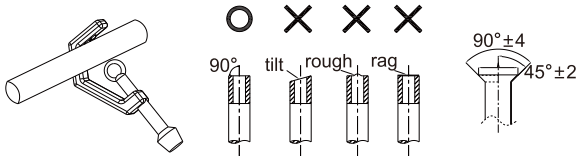

Outer Diameter (mm)	A (mm)	
	Max.	Min.
φ 6.4	8.7	8.3
φ 9.5	12.4	12.0
φ 12.7	15.8	15.4
φ 15.9	19.0	18.6
φ 19.1	23.3	22.9
φ 22.2	27.3	27.0

### 2. Clamp nut

Aimed at connecting piping, tight coupling nut by hand, and then using a wrench and tighten.

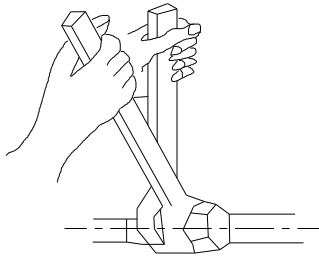

Pipe size	Tightening torque N. m
φ 6.4	14.2-17.2 N.m (144-179kgf.cm)
φ 9.5	32.7-39.9 N.m (333-407kgf.cm)
φ 12.7	49.5-60.3N.m (504-616kgf.cm)
φ 15.9	61.8-75.4 N.m (630-770kgf.cm)
φ 19.1	97.2-118.6 N.m (990-1210kgf.cm)
φ 22.2	109.5-133.7 N.m (1115-1364kgf.cm)

### Note:

1. In order to prevent internal piping nitride, Nitrogen filling operations must be taken when the piping is welding, otherwise oxidation chip will plug the refrigerant cycling.
2. Excessive torque will damage pipe socket, and a small torque of the screw will leak, according to the installation conditions, .Please refer to table Tightening torque.

## Piping size and connection Method

### Pipe catalogue

Piping name	Piping connecting position	Code
Main Tube	between outdoor unit and the 1st. branch pipe	L1
Main Pipe for IDU	between branch pipe and branch pipe	L2~L5
Branch pipe for IDU	between branch pipe and indoor unit	a,b,c,d,e,f
Piping components	Branch pipe	A,B,C,D,E

### Connection method 1

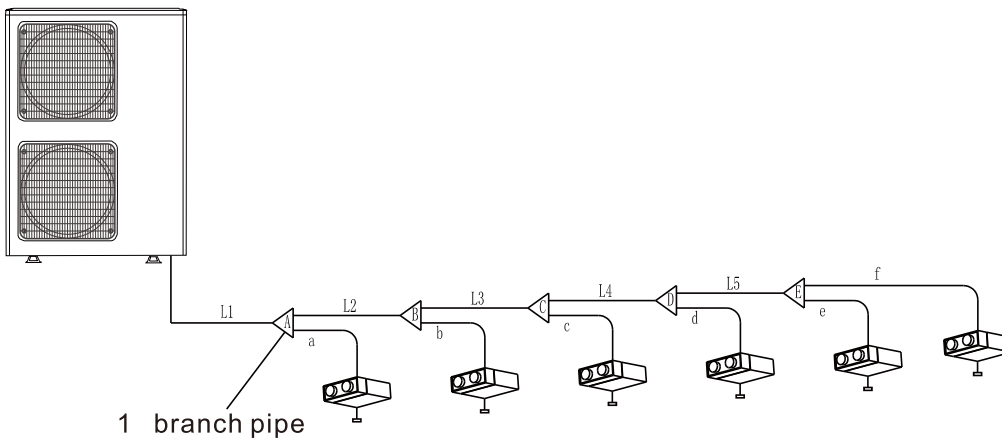



## Connection method 2

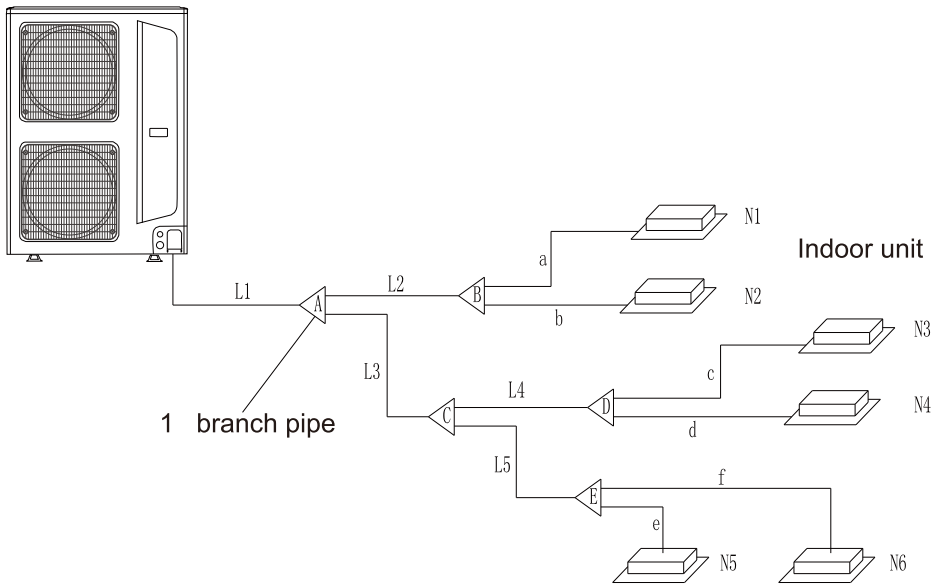

### Note:

- All pipe must adopt our special branch pipe.
- The length between 1st branch pipe to last indoor unit is more than 15m, please choose the second connection method.
- The length between indoor unit and nearest branch pipe must be no more than 15m.

### Connecting pipe diameter

Capacity	Diameter of main tube(all piping equivalent length $\geq 90\text{m}$ )	
	Gas side(mm)	Liquid side(mm)
30000Btu(8kW) 36000Btu(10kW)	$\phi 19.05$	$\phi 9.52$
42000Btu(12kW) 48000Btu(14kW) 60000Btu(16kW)	$\phi 22.2$	$\phi 9.52$
80000Btu(22.4kW) 100000Btu(26kW)	$\phi 28.6$	$\phi 9.52$

### Note:

1. The distance between copper pipe bend and branch pipe should be at least 0.5 m.
2. The distance between two branch pipe should be at least 0.5 m.
3. The distance between indoor unit and branch pipe should be at least 0.5 m.
4. Pipe diameter selection according to maximum principle.

### Attachment connecting pipe diameter size

- step 1: The connecting pipe into the copper nut.
- step 2: Welding with outdoor unit main pipe.
- step 3: Copper nano and stop valve connection.

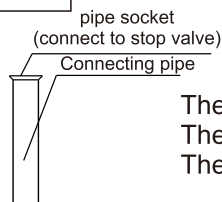

The size of 12/14kW connecting pipe is  $\phi 15.88$ .  
The size of 16kW connecting pipe is  $\phi 19.05$ .  
The size of 22.4/26kW connecting pipe is  $\phi 22.2$ .

Outdoor unit	Max. No. of IDU
30000Btu(8kW)	4
36000Btu(10kW)	5
42000Btu(12kW)	7
48000Btu(14kW)	8
60000Btu(16kW)	9
80000Btu(22.4kW)	13
100000Btu(26kW)	15

### Note:

The total capacity of indoor units can not exceed 130% capacity of outdoor unit. With the ability to decay when the super match.

Capacity (x100W)	22	28	36	45	56	71	80	90	100	112	125	140
Capacity (HP)	0.8	1	1.2	1.7	2	2.5	3	3.2	3.7	4	4.5	5

## Illustration

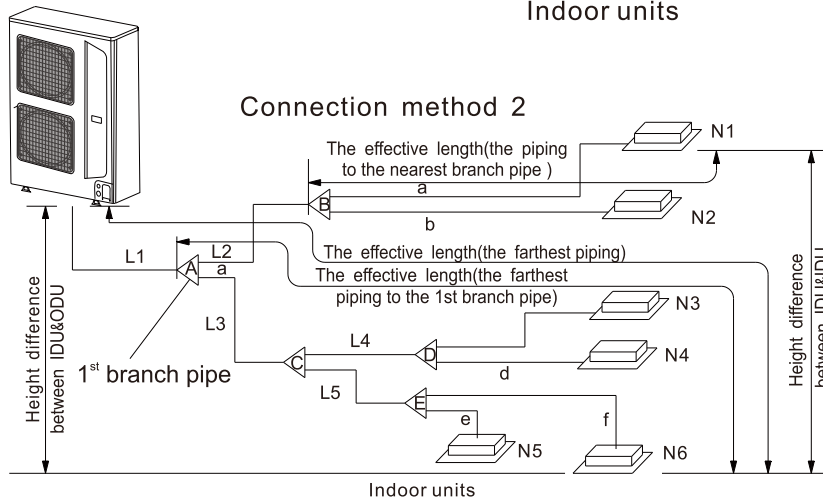
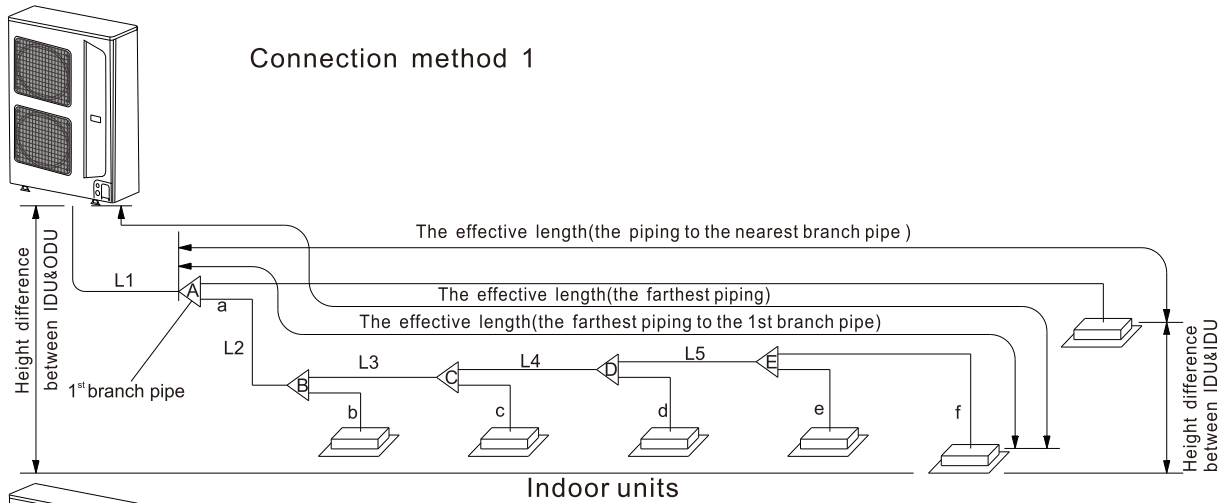

Allow the refrigerant piping length and height difference

				Allowable value		Piping
				≥ 12kW	< 12kW	
8kW 10kW 12kW 14kW 16kW	Piping length	Piping length (Actual length)		≤ 150m	≤ 100m	L1+L2+L3+L4+L5+a+b+c+d+e+f
		The farthest piping (L)	Actual length	≤ 100m	≤ 60m	L1+L2+L3+L4+L5+f (method 1)
			Effective length	≤ 120m	≤ 80m	or L1+L3+L5+f (method 2)
		The effective length (the farthest piping to the 1 <sup>st</sup> branch pipe (L))		≤ 40m	≤ 20m	L1+L2+L3+L4+L5+f (method 1)
The effective length (the piping to the nearest branch pipe (L))		≤ 30m	≤ 15m	or L3+L5+f (method 2)	a, b, c, d, e, f	
Height difference	Height difference between IDU&ODU	ODU upside	≤ 50m	-		
		ODU downside	≤ 40m	-		
	Height difference between IDU&IDU (H)		≤ 15m	≤ 10m	-	
				Allowable value		Piping
22.4kW 26kW	Piping length	Piping length (Actual length)		≤ 250m		L1+L2+L3+L4+L5+a+b+c+d+e+f
		The farthest piping (L)	Actual length	≤ 100m	L1+L2+L3+L4+L5+f (method 1)	
			Effective length	≤ 120m	or L1+L3+L5+f (method 2)	
		The effective length (the farthest piping to the 1 <sup>st</sup> branch pipe (L))		≤ 40m		L1+L2+L3+L4+L5+f (method 1)
The effective length (the piping to the nearest branch pipe (L))		≤ 30m		or L3+L5+f (method 2)		
Height difference	Height difference between IDU&ODU	ODU upside	≤ 50m	-		
		ODU downside	≤ 40m	-		
	Height difference between IDU&IDU (H)		≤ 15m		-	

**Note :** Main tube diameter of gas side must be choosing bigger when all piping equivalent length more than 90m. Besides, main tube diameter of gas side can be choosing bigger when the ability to get smaller, according to the distance of refrigerant pipe and super match for indoor unit.

## Remove the garbage and water from the piping

1. When installing the refrigerant piping, some garbage may enter into the pipe, so before connecting to the outdoor unit, cleaning should be taken.
2. Use high pressure nitrogen gas for cleaning, the refrigerant of outdoor unit is forbidden for cleaning.

## Air tightness Test

1. After finishing the piping connection of outdoor unit, please connect the high pressure side piping and high pressure valve.
2. Make the low pressure side piping and mater joints accessory well-welded.
3. Vacuum pump suction until the gage pressure to draw  $-1\text{kgf/cm}^2$ .
4. Charge the nitrogen( $40\text{kgf/cm}^2$ ) gas from connection point of high side valve and master joints, Retain the pressure for about 24 hours.
5. After the leakage testing, please make the low pressure ball valve and low pressure valve well-welded.

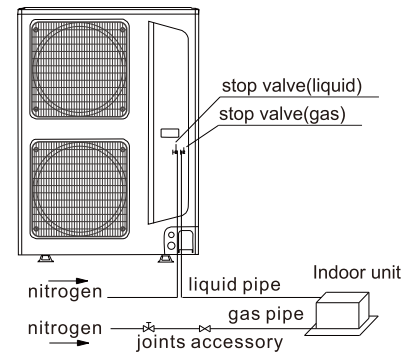

### Note:

- The nitrogen gas( $3.9\text{MPa}$ ,  $40\text{kgf/cm}^2$ ) with a certain pressure is used for the leaking testing.
- It is forbidden directly to charge the nitrogen gas for stop valves(figure4.8).
- It is forbidden to use oxygen, flammable gas and poisonous gas.
- Use wet cloth to wrap the low pressure valve with welding.
- In order to prevent the equipment damage, the retain pressure time should not be too long.

## Use Vacuum Pumps for Vacuuming

1. Use the vacuum pump which relative vacuum degree is  $-0.1\text{MPa}$ , and the displacement is over  $40\text{L/min}$ .
2. Do not open the stop outdoor unit valve of outdoor unit gas side and liquid side because of outdoor unit without vacuum.
3. Vacuum pump work more than 2 hours can achieve relatively vacuum under  $0.1\text{Mpa}$ . If more than 3 hours still can not reach below  $0.1\text{Mpa}$ , that were mixed with water or air, need to check.

### Note:

- Different refrigerant tools and measuring instruments cannot be mixed use.
- Refrigerant gas is not allowed for air exclusion.
- Maybe it is leakage, when relative vacuum degree can't reach  $-0.1\text{MPa}$ . If no leakage, please let the vacuum pump work again one to two hours.

## Stop Valve

1. Stop valve operation and method

### Attention:

- Component name as shown figures. Stop valve is closed when leaving the factory.
- Please use the suitable tools. The unit stop valve is not pipe socket sealed type. Forced open is forbidden, otherwise it will damage the valve.
- Lower operation pressure when low temperature refrigeration runtime for outdoor unit, in order to prevent the gas side stop valve pipe socket is frozen, please use silicon sealant to seal fully.
- Tighten the cover, please confirm whether there is refrigerant leakage.

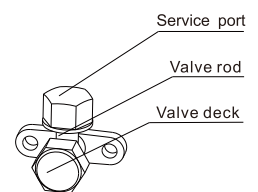

2. Close the stop valve operation and method.

Please prepare Allen wrench (6 mm).

Open method: 1) Use Allen wrench then counterclockwise.  
2) Turn the valve stem stops is open.

Close method: 1) Use Allen wrench then clockwise.  
2) Turn the valve stem stops is close.

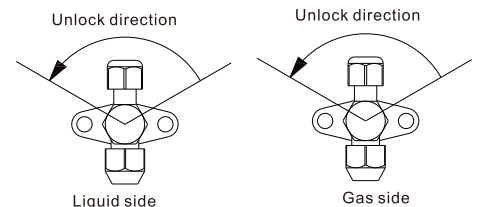

3. Valve deck attention

The valve must tighten the valve deck after operation.

4. Service port attention

Please use a lever operated filling hose. The valve must tighten the valve deck after operation.

Type	30000Btu(8kW) 36000Btu(10kW)	42000Btu(12kW) 48000Btu(14kW) 60000Btu(16kW)	80000Btu(22.4kW) 100000Btu(26kW)
Stop valve (liquid)	Φ 9.52	Φ 9.52	Φ 9.52
Stop valve (gas)	Φ 15.88	Φ 19.05	Φ 22.02

## Leak detection

With soap and water or leak detector check whether each joint leakage.

**Note: A is stop valve(liquid), B is stop valve(gas).  
C and D are connecting pipe port.**

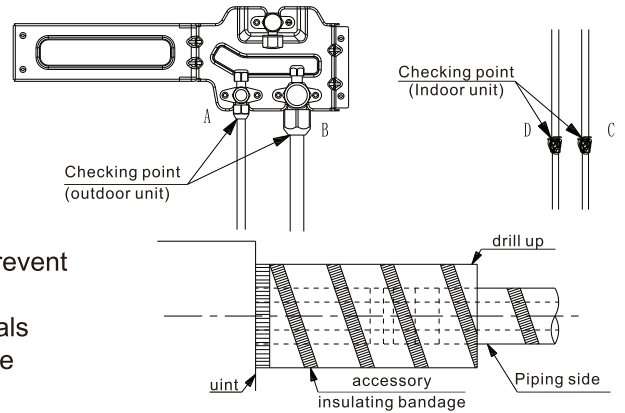

## Heat insulation

Copper tube and drain pipe must be separately insulated to prevent condensation or water leakage.

1. The copper tube should be properly insulated using materials designed for insulating air conditioner pipe and heat resistive above 120°C, and flame retardant B1 level.
2. At least 15 mm of insulation layer thickness of copper pipe diameter  $\leq \varnothing 9.52$ , At least 20 mm of insulation layer thickness of copper pipe diameter  $\geq \varnothing 9.52$ .
3. Piping connection of the indoor unit, please use attached insulation in harmony navigate their insulating.

## Key point of branch pipe installation

Branch pipe should be installed horizontally, as far as possible Angle error is not more than 10°. If the installation is not correct, may result in product failure.

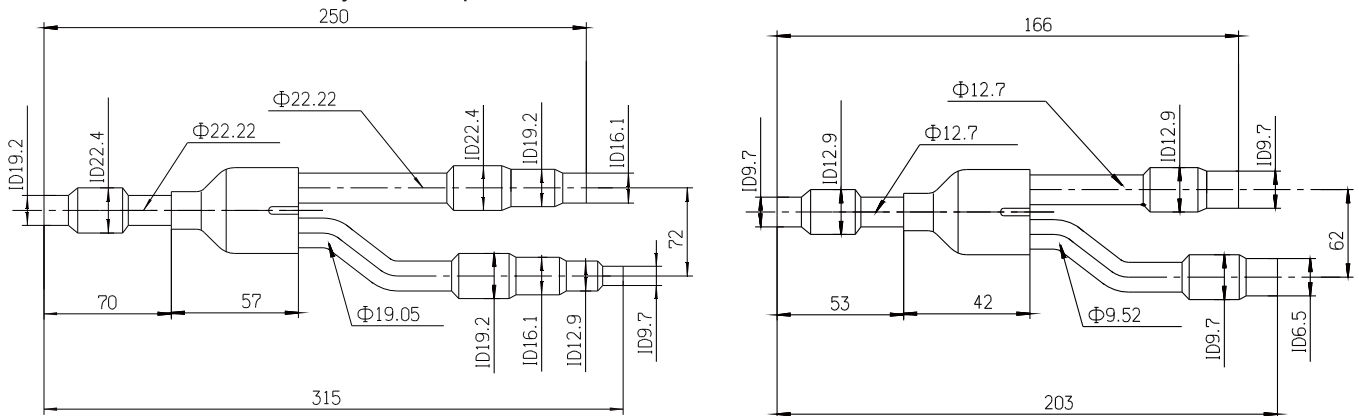

## Refrigerant charging

1. How to calculate refrigerant charging quantity

Depending on liquid piping length

Quantity =  $\sum$  liquid piping length  $\times$  refrigerant charging quantity of per meter

Liquid piping refrigerant charging (kg/m)							
Pipe diameter	$\Phi 25.4$	$\Phi 22.2$	$\Phi 19.05$	$\Phi 15.9$	$\Phi 12.7$	$\Phi 9.52$	$\Phi 6.35$
Refrigerant charging	0.45	0.34	0.25	0.17	0.11	0.054	0.022

**Note:**

- Outdoor unit cooling capacity  $< 12\text{kW}$ , if total liquid piping length within 20m, no need add refrigerant ;
- Outdoor unit cooling capacity  $\geq 12\text{kW}$ , if total liquid piping length within 25m, no need add refrigerant ;
- Outdoor unit cooling capacity  $\geq 22.4\text{kW}$ , according to the diameter and length of the liquid side connection pipe for outdoor unit and indoor unit to calculate the extra refrigerant value.

After Vacuum pumping, when the compressor is not working, the R410a refrigerant is added to the unit from the injection port of the ODU liquid stop valve until the required refrigerant is filled. When it is found that the refrigeration dose can not be filled quickly due to the pressure rise in the tube, the unit can be placed in the refrigeration start-up state and refrigerant filling can be carried out from the low-pressure overhaul opening of the external machine.

**2. Example(16kw outdoor unit)**

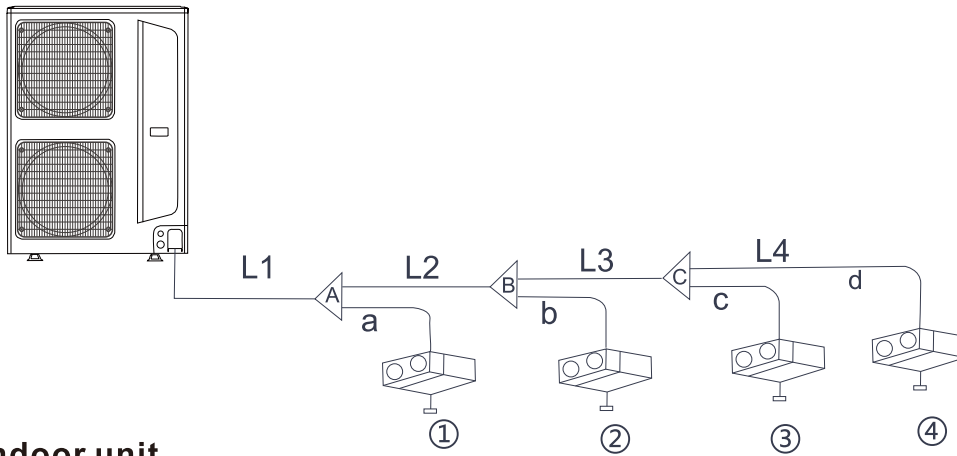

**Indoor unit**

No.	①	②	③	④
Model	7.1kW	4.0kW	2.8kW	2.2kW

**Liquid piping length**

No.	L1	L2	L3	L4
Diameter(mm)	Φ9.52	Φ9.52	Φ9.52	Φ6.35
Length(m)	15m	8m	7m	5m

No.	a	L2	L3	L4
Diameter(mm)	Φ9.52	Φ6.35	Φ6.35	Φ6.35
Length(m)	5m	5m	5m	5m

**Total piping length:**

Φ9.52 :  $L1+L2+L3+a=35m$       Φ6.35 :  $L4+b+c+d=20m$

※ For 16kW , total liquid piping length within 25m, no need add refrigerant .  
 So , minimum refrigerant charging quantity =  $(35-25) \times 0.054 + 20 \times 0.022 = 0.98kg$

# Electric Wiring

## WARNING

- All electrical works must be carried out & checked by a qualified electrician and must adhere to the IET regulations, local and national legislation and industry best practice. The system must have its own independent power supply. An all pole isolating disconnect switch with at least 3mm contact separation must be installed.
- The power cord and connecting cable should be either as supplied with the unit or otherwise as specified in this manual.
- Do not attempt any electrical works yourself.
- An Earth Leakage Protector, Power Switch and Circuit Breaker or Fuse must be installed in the dedicated power supply or there is the risk of electric shock.
- The fuse specification of single-phase control panel is F5AL 250V;
- The grounding must be reliable. If grounding is not correct, it may lead to electric shock.
- All power cables should be properly secured with cable ties so that external forces cannot disconnect the wires from the terminals. Improper connections or insecure fastening can cause electric shocks or fire.
- If the supply cord is damaged, it must be replaced by the manufacturer, its service agent or similarly qualified persons in order to avoid a hazard.

## CAUTION

- Do not connect the earth cable to gas or water pipes, telephone lines, lightning rods or the earth cables of other products.
- Once the indoor and outdoor unit have been switched on, do not cut off power off power supply in 1 minute, (the system automatically set) otherwise abnormal operation will be caused.

- Please connect the power cord and interconnecting cable according to the wiring diagram.
- Connect the wire firmly to the terminal block using crimps and secure in order to prevent external forces pulling on the wire causing risk of fire or electric shock.
- After the electrical connection is completed, all wires should be prevented from touching other parts such as tubing, compressor etc.

### Electrical system and installation

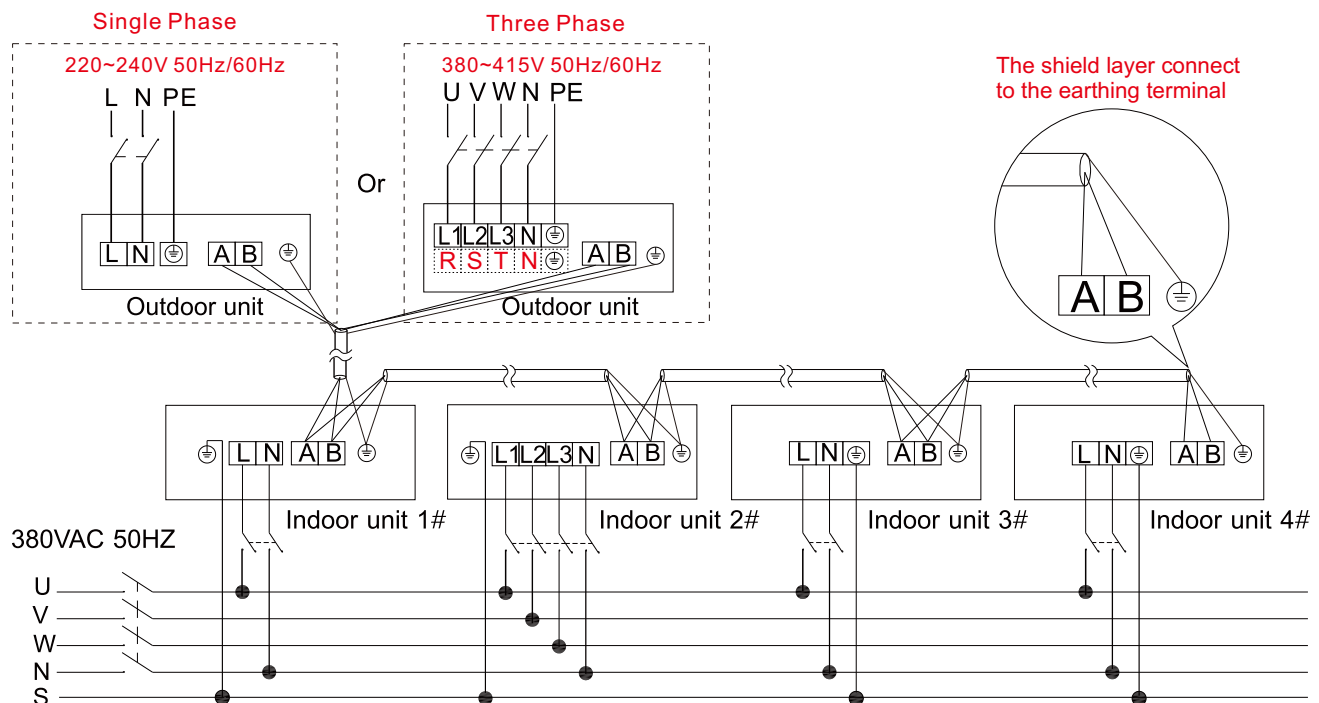

## Indoor unit and outdoor unit wiring system

Recommended Specification for Power Line of Outdoor Unit (stand-alone power supply)

Model \ Item	Power supply	Nominal Cross-Sectional Area(mm <sup>2</sup> )	Wiring length(m)	Rated current breaker(A)
30000Btu(8kW) 36000Btu(10kW)	220V/50Hz	4	20	32
42000Btu(12kW) 48000Btu(14kW)		6		
60000Btu(16kW)				
42000Btu(12kW) 48000Btu(14kW) 60000Btu(16kW)	380V/50Hz	1.5		16
80000Btu(22.4kW) 100000Btu(26kW)		6		32

### NOTE:

- In any case, the ground plane shall not disconnect the main power switch.
- Shall not use the damaged power cord, if found damaged should be replaced immediately.
- The air-conditioner use or power is a long time for the first time, need to preheat the turning on the power supply for at least 12 hours before use.
- In the table is said to gravitate diameter and length of continuous voltage drop within 2%, when the wiring for length exceeds the value in the table, please follow the relevant provisions of the selected wire and wire diameter.

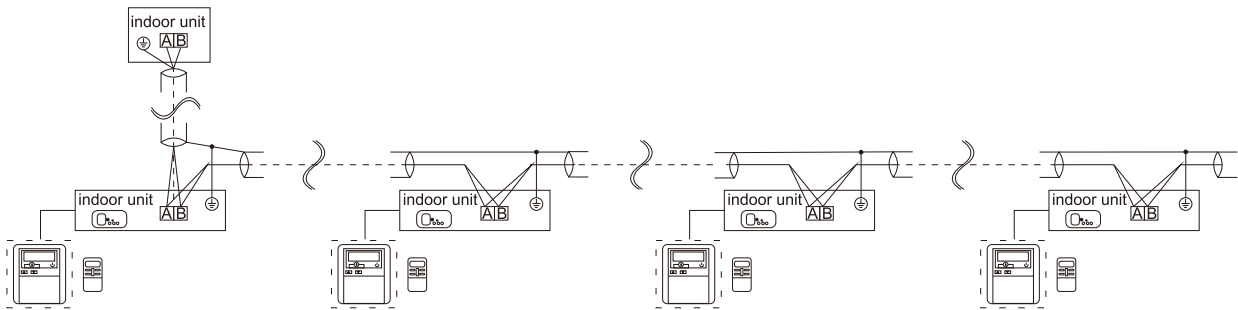

### ⚠ Note

- When power wire is parallel with signal wire, put wires to their own wire tube and remain proper gap. The distance between the power wire and signal wire is appropriate. Recommended distance : below 10A -300mm, below 50A -500mm,
- The communication line between indoor units and outdoor units must use 3 core shielded wiring, and shielding layer is earth according to the requirements.
- Outdoor supply cords shall not be lighter than polychloroprene sheathed flexible cord with code designation 60245 IEC 57. Please refer to the unit wiring system for specifications.
- Outdoor supply cords shall not be lighter than polyvinyl chloride flexible cord with code designation 60227 IEC 53. Please refer to the unit wiring system for specifications.

## Digital tube display

### SW1: Refrigerating capacity selection

Capacity		SW1			
T1	T3	1	2	3	4
8kW		0	0	0	0
10kW	8kW	0	0	0	1
12kW	10kW	0	0	1	0
14kW	12kW	0	0	1	1
16kW	14kW	0	1	1	1
18kW		0	1	0	1
20kW		0	1	1	0
22.4kW	16kW	0	1	0	0
26kW	18kW	1	0	0	0
28kW		1	0	0	1
30kW		1	0	1	0
33.5kW		1	0	1	1
40kW		1	1	0	0
45kW		1	1	0	1
50.4kW		1	1	1	0

### SW2: Function selection

1	1	26°C economic locking
	0	without 26°C economic locking(default)
2	1	Auto addressing
	0	Manual addressing
3	1	Cool mode first
	0	First match wins (default)
4	1	AC Motor
	0	DC Motor

### SW3: Function selection

1	1	Undefined
	0	Undefined
2	1	Without heating for 6hours after power on
	0	Heating for 6hours after power on
3	1	Silent mode
	0	Without silent (default)
4	1	Locking indoor unit No
	0	Unlocking indoor unit No (default)

### SW4 function definition:Function selection

Model	SW4			
	1	2	3	4
R410	0	0	0	0
R32	0	0	0	1
Type A	0	0	1	0
Three phase power	0	0	1	1

Notes:

ON



"means1"

ON



"means0"

Dial steps:

1. Set the second bit of SW2 to "ON" and start automatic addressing. If WiFi module is installed, it must be manually addressed; (power-off operation)
2. When the number of digital tube is the same as the actual number and keep 1 minute, set the fourth bit of SW3 to "ON" to lock the number of internal unit; (power operation)
3. Set the second bit of SW3 to "ON" and shield the heating function of power-up 6 hours (according to the actual situation). (Power-off operation)

## Fault Code

Fault code definition	
Fault Code	Definition of Fault Code
C1	ENV Sensor "Tao" failure
C2	Defrost Sensor "Tdef" failure
C3	Exhaust Sensor "Tda" failure
C6	Compressor suction sensor "Ts" failure
CJ	Oil temperature sensor "Tci" failure
F1	High pressure sensor "Pd" failure
F3	High pressure "Pd" protection
F6	Low pressure "Ps" protection
FB(FH)	Low discharge temperature "Tda" protection
H1	High pressure switch "HPS" protection
H4	Low pressure switch "LPS" failure
E1	4-way valve failure
H5	Lack of gas alarm
HE(HB)	AC power input high



Fault Code	Definition of Fault Code
HJ	Lack of phase/Inverse phase
E3	Discharge temperature "Tda" too high shutdown protection
J2	The communication between indoor unit and outdoor unit failed
J3	The communication between Controller and module failure
J4	The communication between main control panel and fan1 failed
J5(D5)	Outdoor unit parameter setting incorrect
J7	Outdoor unit Controller EPROM module(AT24C04) failure
J9	The communication between main control panel and fan2 failed
JJ	capacity exceeding failure
31	Compressor drive Module protection (F0)n
32	Compressor drive Module hardware protection
33	Compressor drive Module software protection
34	Compressor unconnected
35	Compressor phase current overcurrent protection
36	DC bus overvoltage or undervoltage protection
37	Compressor temperature sensor of driver module heat fins failure
38	Compressor driver module high temperature limit frequency failure
39	Compressor driver module high temperature, shur down protection
3E	Compressor drives ac input current protection
3F	Compressor drive module PFC protection
3H	Dc fan motor drive module start failure or running out of step
47	Indoor unit loss failure
E9	The temperature of driving cooling pipe too low
5H(B)	Dc fan motor2 drive module start failure or running out of step
41	Dc fan 1 drive panel IPM alarm
43	Dc fan 1 drive board hardware protection
49	Dc fan 2 drive panel IPM alarm
4H	Dc fan 2 drive board hardware protection
3C	Dc fan 1 overcurrent protection
5C	Dc fan 2 overcurrent protection
3J	Dc fan 1 DC undervoltage protection
5J	Dc fan 2 DC undervoltage protection
3A	Dc fan 1 module temperature protection
5A	Dc fan 2 module temperature protection

## Prevention of Refrigerant Leakage

- The refrigerants used in air conditioners are R22, R410A and R407C. The refrigerants are harmless and non-flammable safe refrigerants.
- The room with air conditioning requires a moderate space size. In case of refrigerant leakage, it will not exceed the limit concentration. In addition, necessary measures can be taken.
- Limit Concentration: Upper limit of freon concentration not hazardous to human body.  
 limit concentration of R22: 0.3[kg/m<sup>3</sup>].  
 limit concentration of R407C: 0.35[kg/m<sup>3</sup>].  
 limit concentration of R410a: 0.44[kg/m<sup>3</sup>].

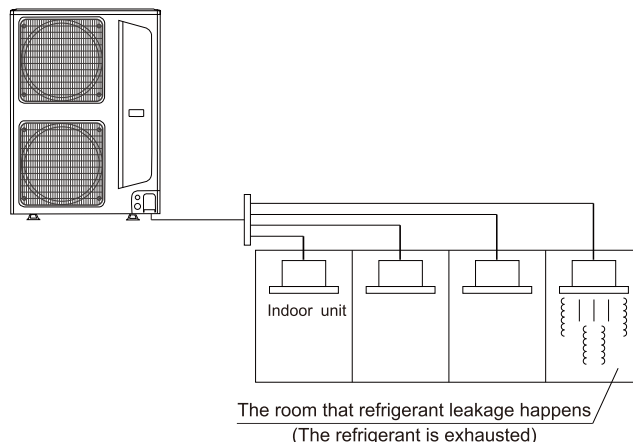

### Countermeasure for excessive concentration

1. In order to reduce the concentration under the limit, you are strongly recommended to install mechanical hood(ventilation should be usual).
2. Please install leakage alarming device connected to mechanical ventilation equipment when frequent ventilation is impossible.

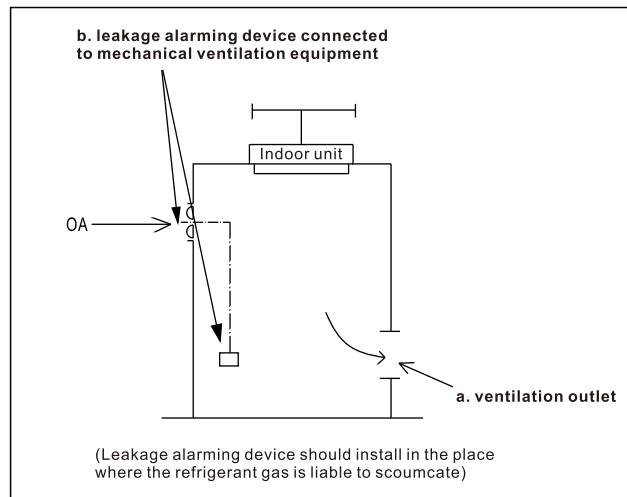

## Trail Operation

### Checking before trail operation

1. Indoor unit and outdoor unit is properly installed.
2. The piping and wiring is correct.
3. Refrigerant piping system is leak detection.
4. Heat insulation is perfect.
5. Ground wire is properly connected.
6. The length of the pipe and the additional quantity of refrigerant has been recorded.
7. Power supply voltage and rated voltage of air condition is equal.
8. Inlet and outlet of indoor unit and outdoor unit is not obstacles.
9. Open stop valve.
10. Switch on the power to let the air conditioner warm.

### Trail operation

1. Indoor unit
  - 1) Remote controller is normal.
  - 2) All buttons are normal.
  - 3) Wind deflector movement is normal.
  - 4) Room temperature adjustment is normal.
  - 5) Indicator light is normal.
  - 6) Manually run button is normal.
  - 7) Drainage is normal.
  - 8) There is no vibration and abnormal sound.
  - 9) Test the heating mode is normal.
2. Outdoor unit
  - 1) There is no vibration and abnormal sound.
  - 2) The noise and air of outdoor unit impacts the normal life of local people.
  - 3) No refrigerant leakage.

### NOTE:

After turning on the power supply, immediately turned on or off when the reboot, air conditioner equipped with protection function, compressor delay start 5 minutes.



## DE-COMMISSIONING, DISMANTLING & DISPOSAL

This product contains refrigerant under pressure, rotating parts, and electrical connections which may be a danger & cause injury. All work must only be carried out by competent persons using suitable protective clothing and safety precautions.



Read the Manual



Risk of Electric Shock

**RoHS**



Unit is Remotely controlled  
& may start without warning



1. Isolate all sources of electrical supply to the unit including any control system supplies switched by the unit. Ensure that all points of electrical and gas isolation are secured in the OFF position. The supply cables and gas pipe work may then be disconnected and removed. For points of connection refer to unit installation instructions.
2. Remove all refrigerant from each system of the unit into a suitable container using a refrigerant reclaim or recovery unit. This refrigerant may then be reused, if appropriate, or returned to the manufacturer for disposal. Under NO circumstances should refrigerant be vented to atmosphere. Where appropriate, drain the refrigerant oil from each system into a suitable container and dispose of according to local laws and regulations governing disposal of oily wastes.
3. Packaged units can generally be removed in one piece after disconnection as above. Any fixing down bolts should be removed and then unit lifted from position using the points provided and equipment of adequate lifting capacity. Reference MUST be made to the unit installation instructions for unit weight and correct methods of lifting. Note that any residual or spilt refrigerant oil should be mopped up and disposed of as described above.
4. After removal from position the unit parts may be disposed of according to local laws and regulations.
5. Meaning of crossed Out wheeled dustbin: Do not dispose of electrical appliances as unsorted municipal waste, use separate collection facilities. Contact your local government for information regarding the collection systems available. If electrical appliances are disposed of in landfills or dumps, hazardous substances can leak into the groundwater and get into the food chain, damaging your health and well being. When replacing old appliances with new ones, the retailer is legally obligated to take back your old appliance for disposals at least free of charge.